

Chapter 8 Option Cards

8-1 Option Card Installation

8-2 EMC-D42A -- Extension card for 4-point digital input/ 2-point digital input

8-3 EMC-D611A -- Extension card for 6-point digital input (110V_{AC} input voltage)

8-4 EMC-R6AA -- Relay output extension card (6-point N.O. output contact)

8-5 EMC-BPS01 -- +24V power card

8-6 EMC-A22A -- Extension card for 2-point analog input/ 2-point analog output

8-7 EMC-PG01L / EMC-PG02L -- PG card (Line driver)

8-8 EMC-PG01O / EMC-PG02O -- PG card (Open collector)

8-9 EMC-PG01U / EMC-PG02U -- PG card (ABZ Incremental encoder signal/ UVW
Hall position signal input)

8-10 EMC-PG01R -- PG card (Resolver)

8-11 EMC-PG01H -- PG card (Resolver)

8-12 CMC-PD01 -- Communication card, PROFIBUS DP

8-13 CMC-DN01 -- Communication card, DeviceNet

8-14 CMC-EIP01 -- Communication card, EtherNet/IP

8-15 CMC-EC01 -- Communication card, EtherCAT

8-16 CMC-PN01 -- Communication card, PROFINET

8-17 EMC-COP01 -- Communication card, CANopen

8-18 Delta Standard Fieldbus Cables

- The option cards in this chapter are optional accessories. Select the applicable option cards for your motor drive, or contact your local distributor for suggestions. The option cards can significantly improve the efficiency of the motor drive.
- To prevent damage to the motor drive during installation, remove the digital keypad and the cover before wiring.
- The option cards do not support hot swapping. Power off the motor drive before you install or remove the option cards.

8-1 Option Card Installation

8-1-1 Remove the top cover

Frame A–C

Screw Torque: 8–10 kg-cm / [6.9–8.7 lb-in.] / [0.8–1.0 Nm]

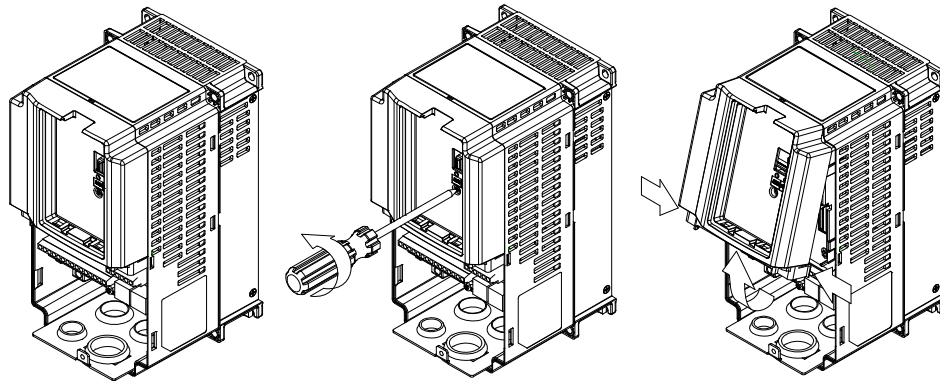

Frame D0

Screw Torque: 8–10 kg-cm / [6.9–8.7 lb-in.] / [0.8–1.0 Nm]

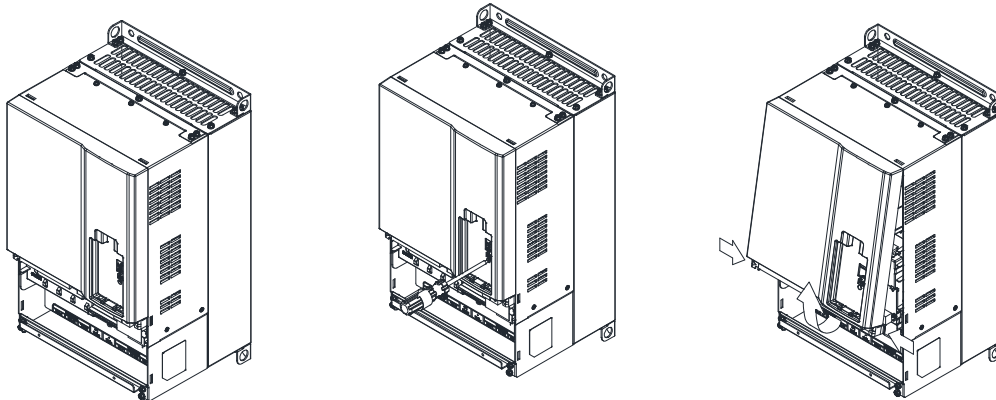

Frame D

Screw Torque: 8–10 kg-cm / [6.9–8.7 lb-in.] / [0.8–1.0 Nm]

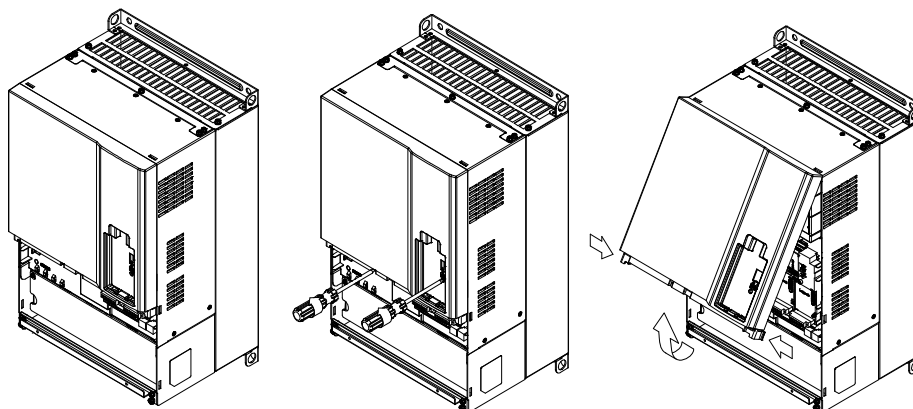

Frame E

Screw Torque: 12–15 kg-cm / [10.4–13 lb-in.] / [1.2–1.5 Nm]

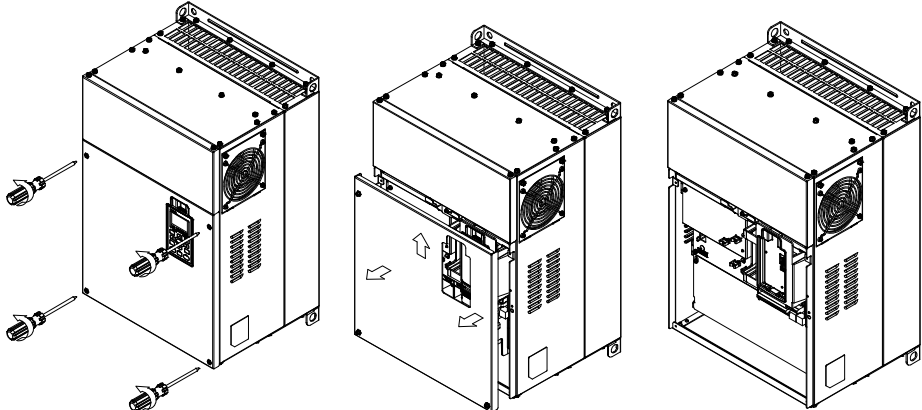

Frame F

Screw Torque: 12–15 kg-cm / [10.4–13 lb-in.] / [1.2–1.5 Nm]

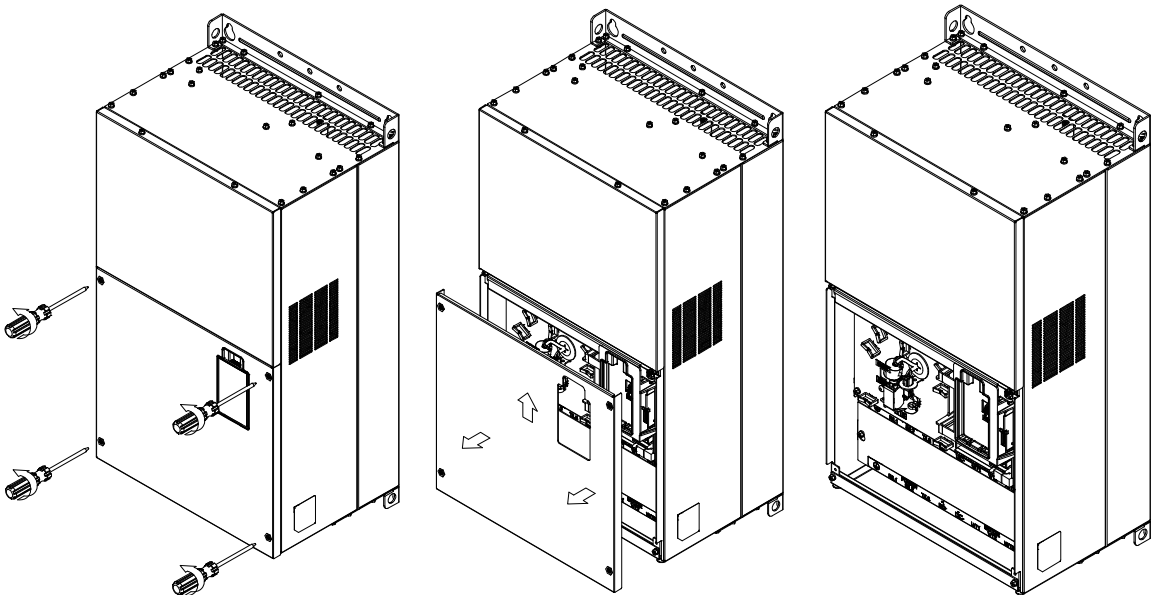

Frame G

Screw Torque: 12–15 kg-cm / [10.4–13 lb-in.] / [1.2–1.5 Nm]

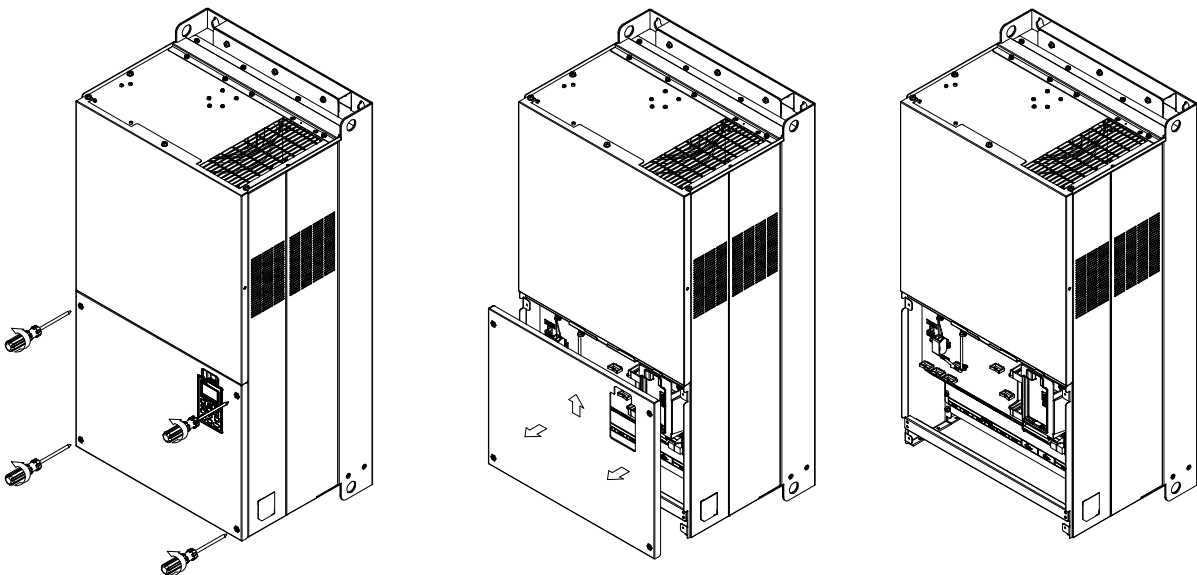

Frame H

Screw Torque: 14–16 kg-cm / [12.15–13.89 lb-in.] / [1.4–1.6 Nm]

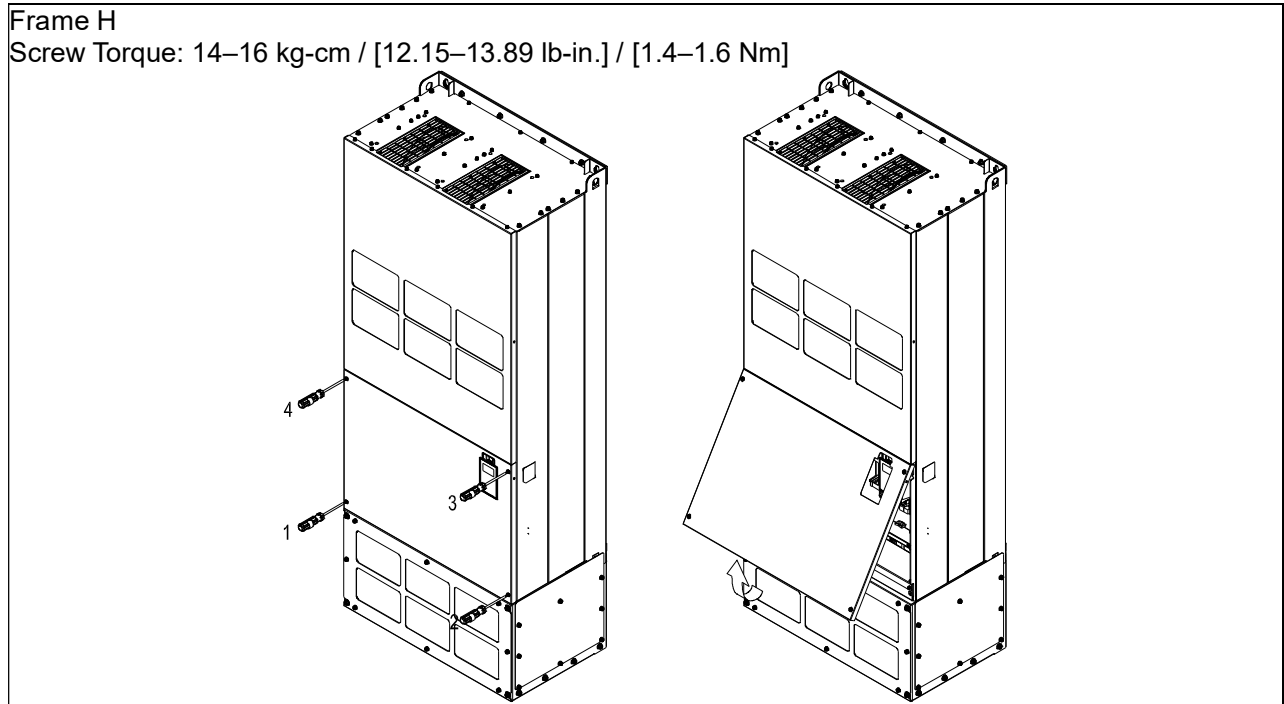

8-1-2 Option Card Installation Location

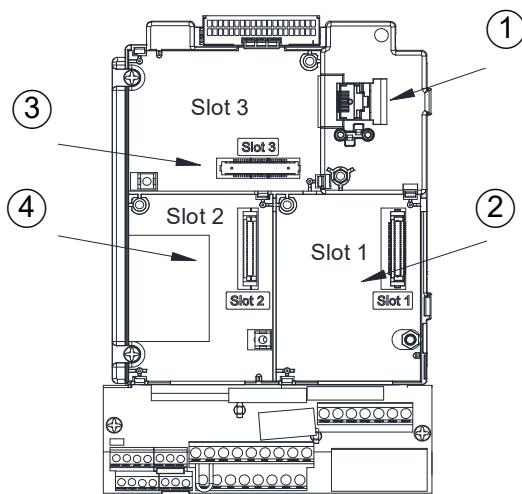

1	RJ45 (Socket) for digital keypad KPC-CC01 <input checked="" type="checkbox"/> Refer to CH10 Digital Keypad for more details on KPC-CC01. <input checked="" type="checkbox"/> Refer to CH10 Digital Keypad for more details on optional accessory RJ45 extension cable.
2	Communication extension card (Slot 1) CMC-PD01; CMC-DN01; CMC-EIP01; EMC-COP01; CMC-EC01; CMC-PN01
3	I/O & Relay extension card (Slot 3) EMC-D42A; EMC-D611A; EMC-R6AA; EMC-BPS01; EMC-A22A
4	PG Card (Slot 2) EMC-PG01L; EMC-PG02L; EMC-PG01O; EMC-PG02O; EMC-PG01U; EMC-PG02U; EMC-PG01R; EMC-PG01H

Screws Specification for option card terminals:

EMC-D42A; EMC-D611A; EMC-BPS01	Wire gauge	0.2–0.5 mm ² [26–20 AWG]
	Torque	5 kg-cm / [4.4 lb-in.] / [0.5 Nm]
EMC-R6AA	Wire gauge	0.2–0.5 mm ² [26–20 AWG]
	Torque	8 kg-cm / [7 lb-in.] / [0.8 Nm]
EMC-A22A	Wire gauge	0.2–4 mm ² [24–12 AWG]
	Torque	5 kg-cm / [4.4 lb-in.] / [0.5 Nm]
EMC-PG01L ; EMC-PG02L ; EMC-PG01O ; EMC-PG02O ; EMC-PG01U ; EMC-PG02U ; EMC-PG01R ; EMC-PG01H	Wire gauge	0.2–0.5 mm ² [26–20 AWG]
	Torque	2 kg-cm / [1.73 lb-in.] / [0.2 Nm]

I/O & Relay extension card (Slot 3)

EMC-D42A

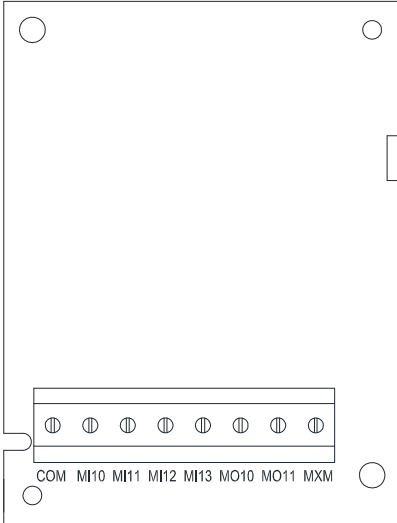

EMC-R6AA

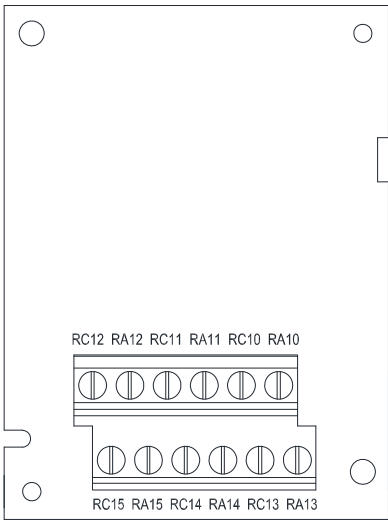

EMC-BPS01

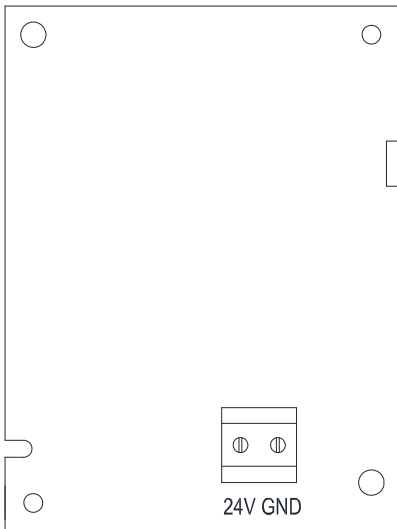

EMC-D611A



EMC-A22A

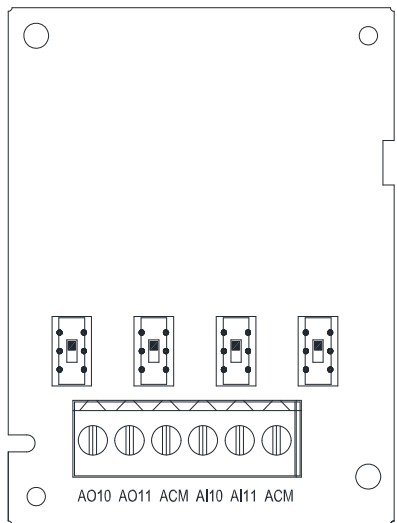

PG card (Slot 2)

EMC-PG010 / EMC-PG020

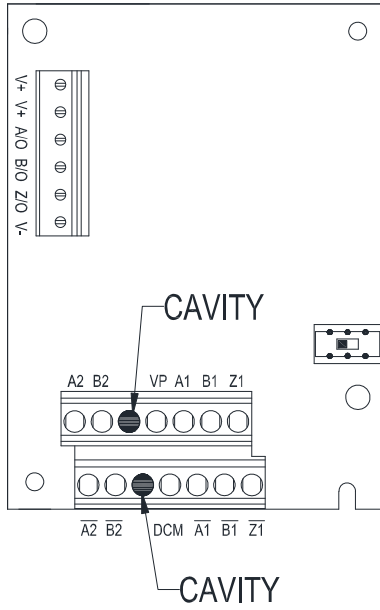

EMC-PG01L / EMC-PG02L

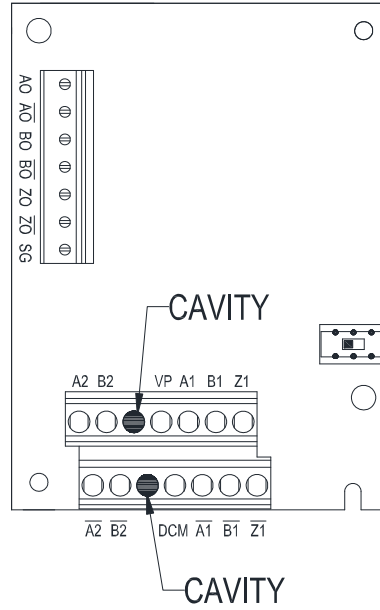

EMC-PG01U / EMC-PG02U

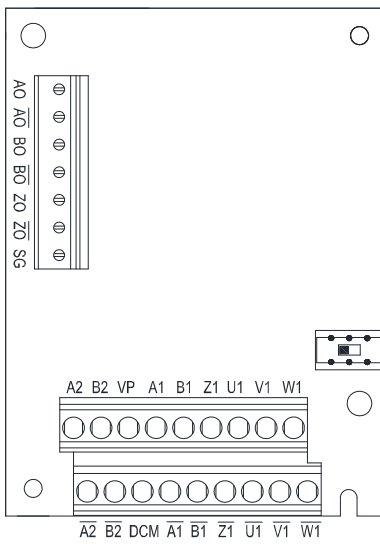

EMC-PG01R

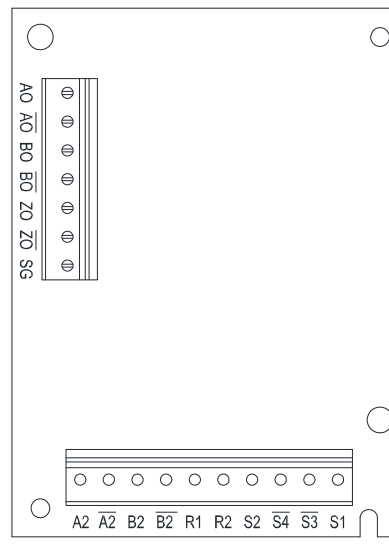

EMC-PG01H

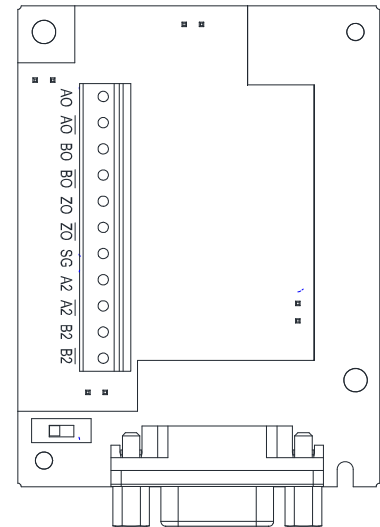

Communication extension card (Slot 1)

CMC-PD01

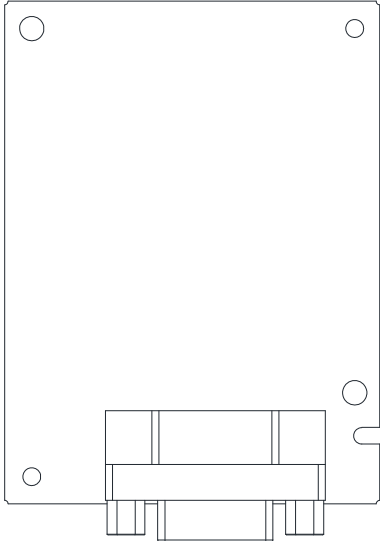

CMC-DN01

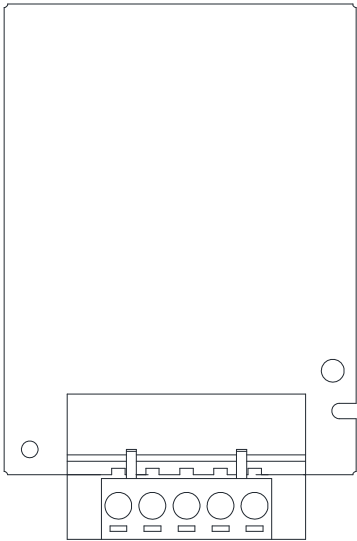

CMC-EIP01

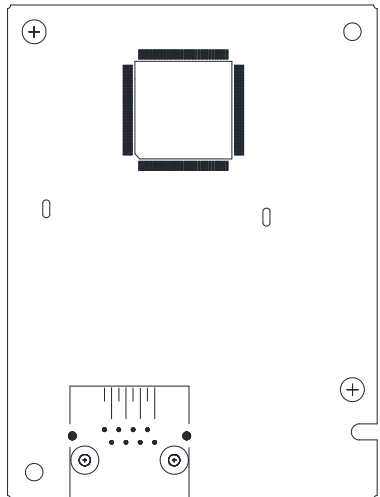

EMC-COP01

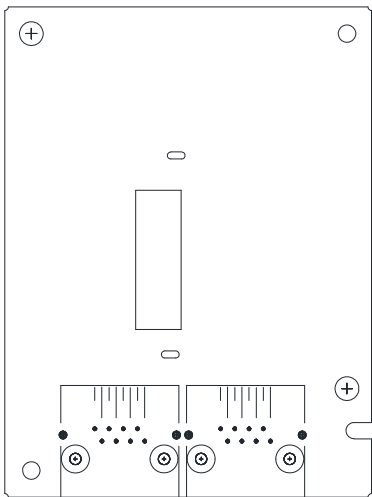

CMC-EC01

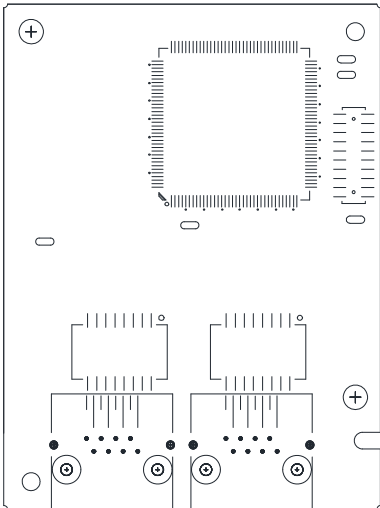

CMC-PN01

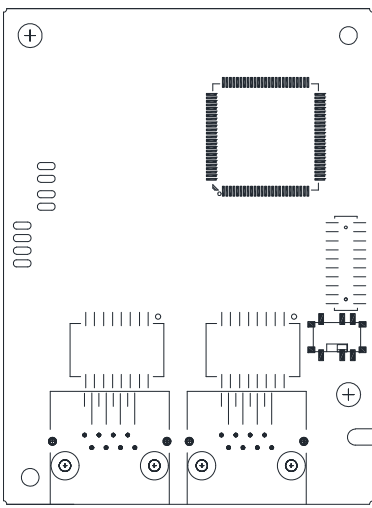

8-1-3 Installation and Disconnection of Extension Card

8-1-3-1 Installation

Communication card: EMC-COP01, CMC-EIP01, CMC-DN01, CMC-PD01, CMC-EC01, CMC-PN01

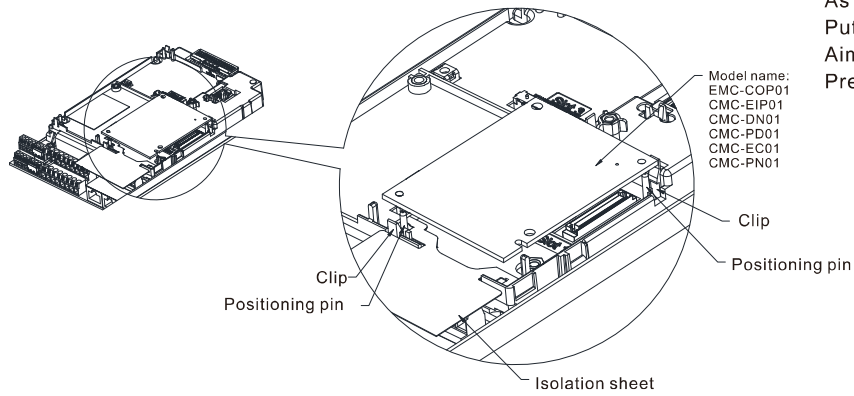

As shown in the figure on the left.
 Put the isolation sheet into the positioning pin.
 Aim the two holes at the positioning pin.
 Press the pin to clip the holes with the PCB.

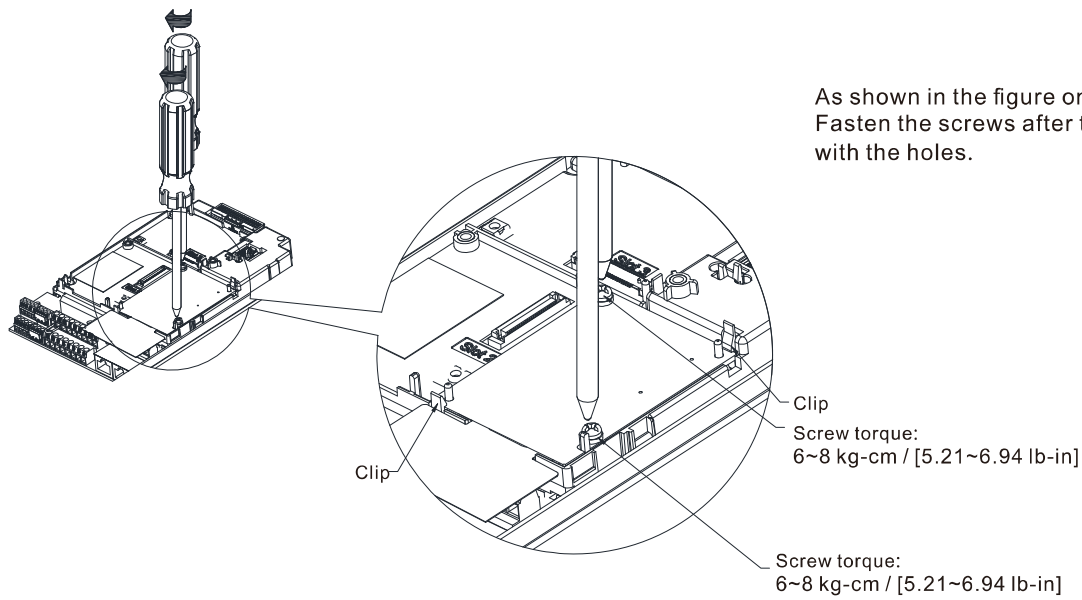

As shown in the figure on the left.
 Fasten the screws after the PCB is clipped
 with the holes.

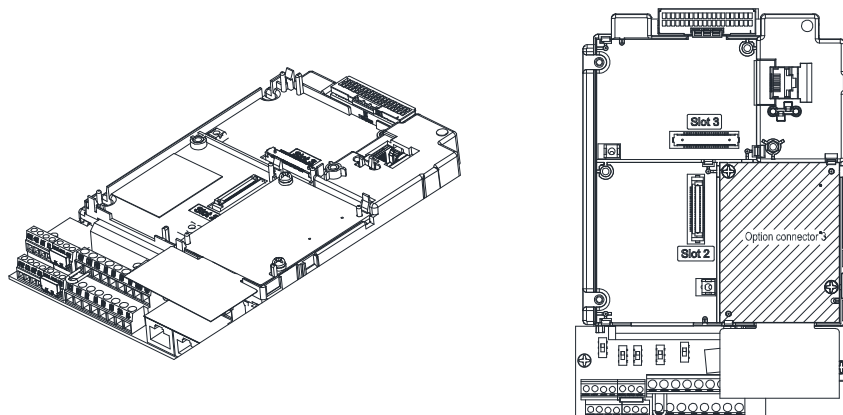

As shown in the figure on the left,
 installation is completed.

I/O & Relay Card: EMC-D42A, EMC-D611A, EMC-R6AA, EMC-BPS01, EMC-A22A

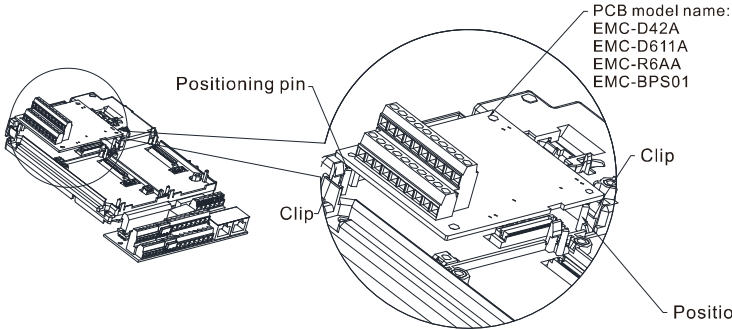

As shown in the figure on the left.
Aim the two holes at the positioning pin.
Press the pin to clip the holes with the PCB.

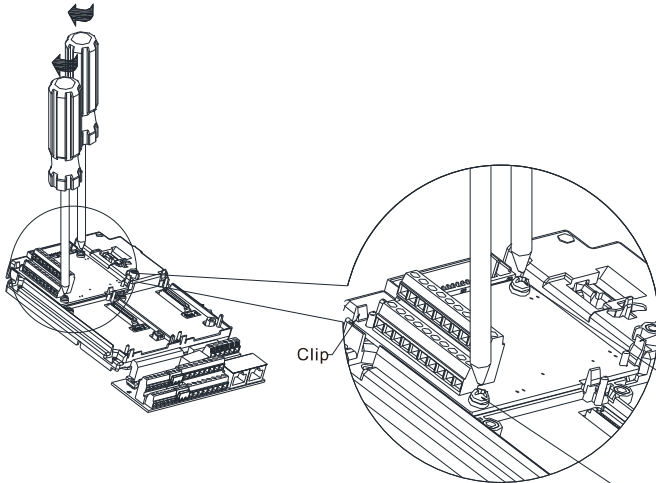

As shown in the figure on the left.
Fasten the screws after the PCB is clipped
with the holes.

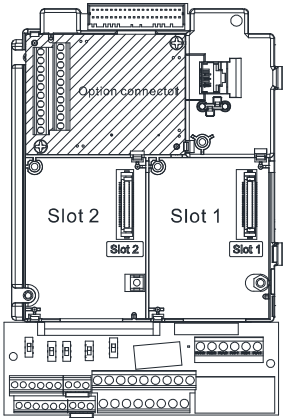
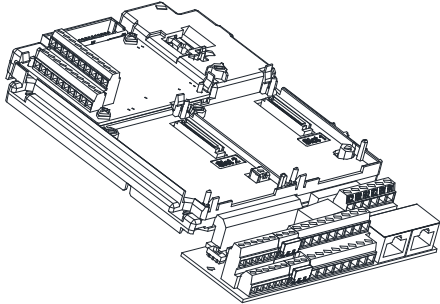

As shown in the figure on the left,
installation is completed.

PG Card: EMC-PG01O / EMC-PG02O, EMC-PG01L / EMC-PG02L, EMC-PG01U / EMC-PG02U,
EMC-PG01R, EMC-PG01H

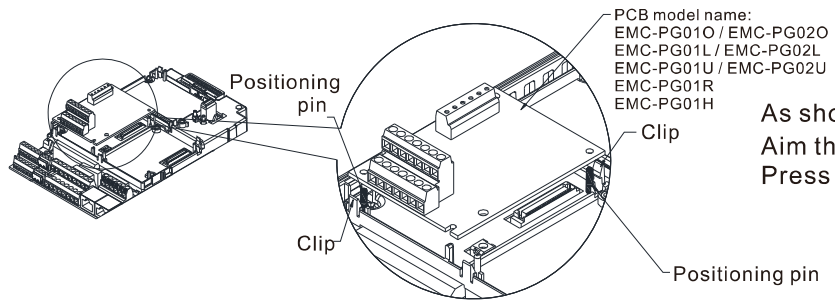

As shown in the figure on the left.
Aim the two holes at the positioning pin.
Press the pin to clip the holes with the PCB.

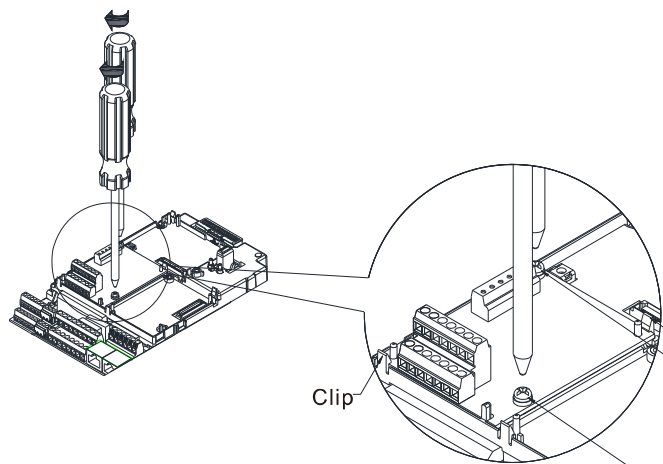

As shown in the figure on the left.
Fasten the screws after PCB is clipped
with the holes.

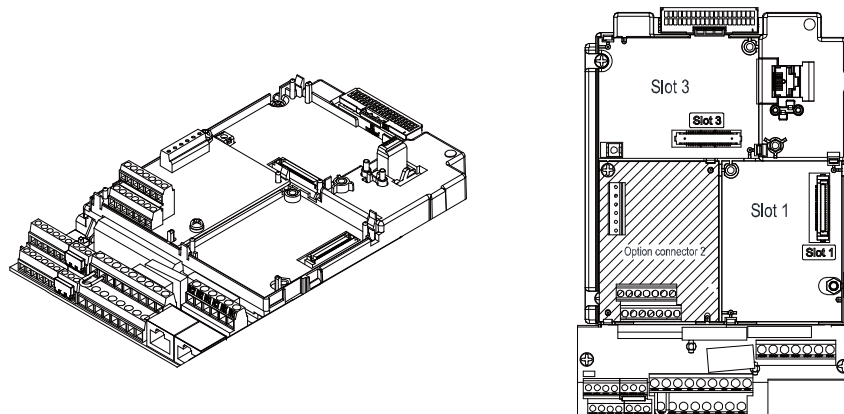

As shown in the figure on the left,
installation is completed.

8-1-3-2 Disconnecting the extension card

Communication card: EMC-COP01, CMC-EIP01, CMC-DN01, CMC-PD01, CMC-EC01, CMC-PN01

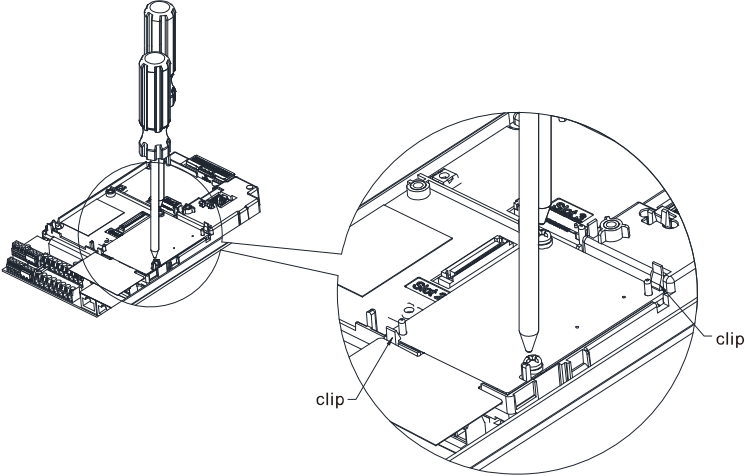

Remove the two screws as shown in the figure on the left.

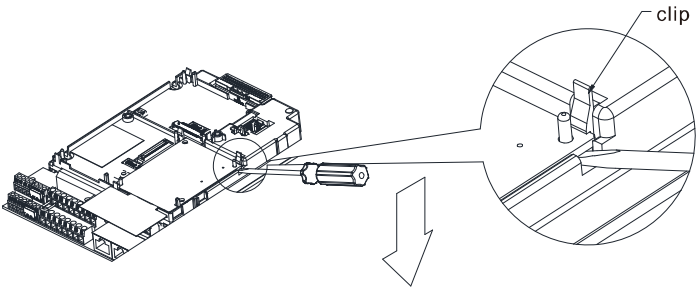

As shown in the figure on the left. Twist to open the clip. Insert a slot type screwdriver into the hollow to prize the PCB off the clip.

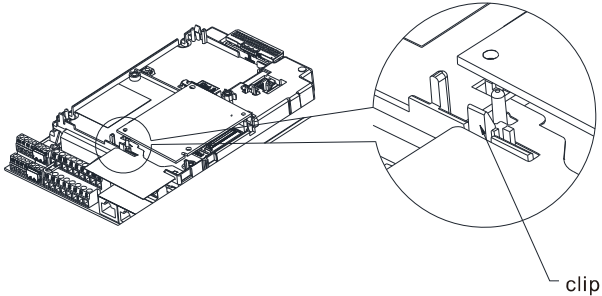

As shown in the figure on the left. Twist to open the other clip to remove the PCB.

I/O & Relay card: EMC-D42A, EMC-D611A, EMC-R6AA, EMC-BPS01, EMC-A22A

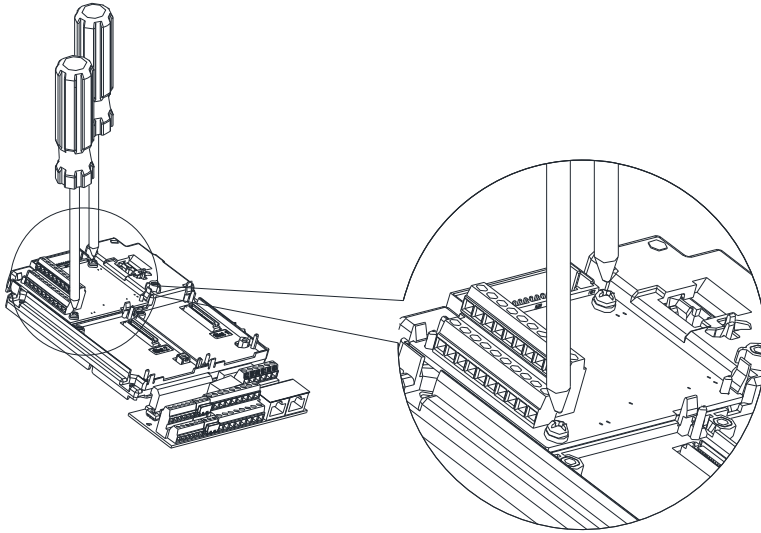

Remove the two screws as shown in the figure on the left.

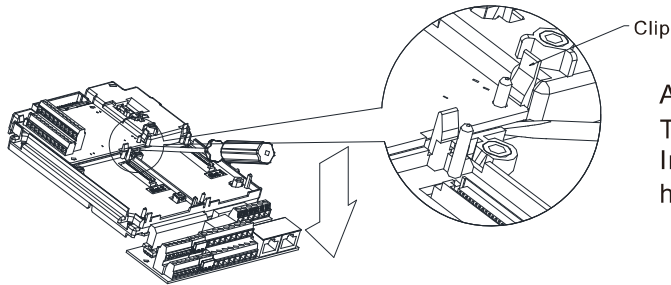

As shown in the figure on the left.
Twist to open the clip.
Insert a slot type screwdriver into the hollow to prize the PCB off the clip.

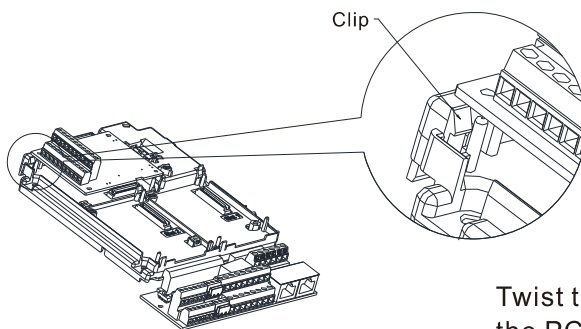

Twist to open the other clip to remove the PCB, as shown in the figure on the left.

PG card: EMC-PG01O / EMC-PG02O, EMC-PG01L / EMC-PG02L, EMC-PG01U / EMC-PG02U,
EMC-PG01R, EMC-PG01H

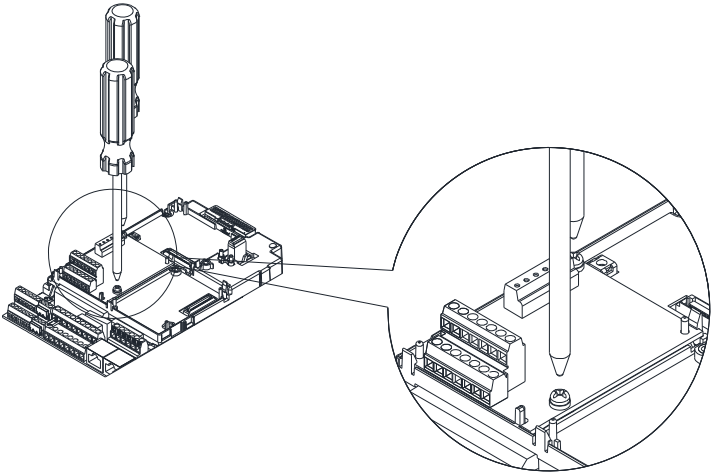

Remove the two screws as shown in the figure on the left.

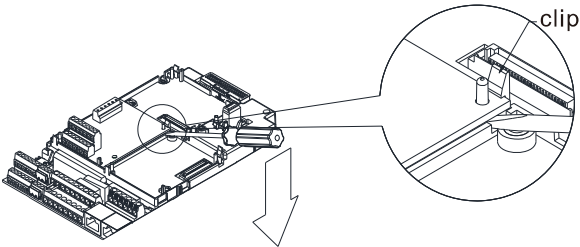

As shown in the figure on the left.
Twist to open the clip.
Insert a slot type screwdriver into the hollow
to prize the PCB off the clip.

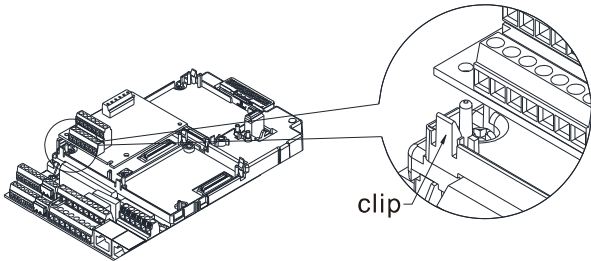

As shown in the figure on the left.
Twist to open the other clip to remove
the PCB.

8-2 EMC-D42A -- Extension card for 4-point digital input/ 2-point digital input

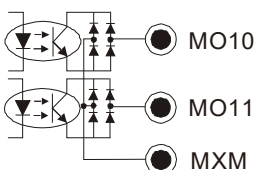
	Terminals	Descriptions
I/O Extension Card	COM	Common for Multi-function input terminals Select SINK (NPN) / SOURCE (PNP) in J1 jumper / external power supply
	MI10–MI13	Refer to Pr.02-26–02-29 to program the multi-function inputs MI10–MI13. Internal power is applied from terminal E24: +24 V _{DC} ± 5% 200 mA, 5W External power +24 V _{DC} : max. voltage 30 V _{DC} , min. voltage 19 V _{DC} , 30W ON: the activation current is 6.5 mA OFF: leakage current tolerance is 10 µA
	MO10–MO11	Multi-function output terminals (photocoupler) The AC motor drive releases various monitor signals, such as drive in operation, frequency attained and overload indication, via transistor (open collector). 
	MXM	Common for multi-function output terminals MO10, MO11 (photocoupler) Max 48 V _{DC} 50 mA

8-3 EMC-D611A -- Extension card for 6-point digital input (110V_{AC} input voltage)

	Terminals	Descriptions
I/O Extension Card	AC	AC power Common for multi-function input terminal (Neutral)
	MI10–MI15	Refer to Pr.02-26–Pr. 02-31 for multi-function input selection Input voltage: 100–130 V _{AC} Input frequency: 47–63 Hz Input impedance: 27 KΩ Terminal response time: ON: 10 ms OFF: 20 ms

8-4 EMC-R6AA -- Relay output extension card (6-point N.O. output contact)

	Terminals	Descriptions
Relay Extension Card	RA10–RA15 RC10–RC15	Refer to Pr.02-36– Pr.02-41 for multi-function output selection Resistive load: 3A (N.O.) / 250 V _{AC} 5A (N.O.) / 30 V _{DC} Inductive load (COS 0.4) 1.2A (N.O.) / 250 V _{AC} 2.0A (N.O.) / 30 V _{DC} It is used to output each monitor signal, such as drive is in operation, frequency attained or overload indication.

8-5 EMC-BPS01 -- +24V power card

	Terminals	Descriptions
External Power Supply	24V GND	Input power: 24 V± 5% Maximum input current: 0.5 A Note: Do not connect drive control terminal GND directly to the EMC-BPS01 input terminal GND. Function: When the drive is only powered by EMC-BPS01, the communication can be assured and support all communication cards and following functions: Parameters read and write Keypad can be displayed Keypad button can be operated (except RUN) Analog input is effective Multi-input (FWD, REV, MI1–MI8) needs external power supply to operate Following functions are not supported : Relay output (including extension card), PG card, PLC function

8-6 EMC-A22A -- Extension card for 2-point analog input/ 2-point analog output

8-6-1 Product File

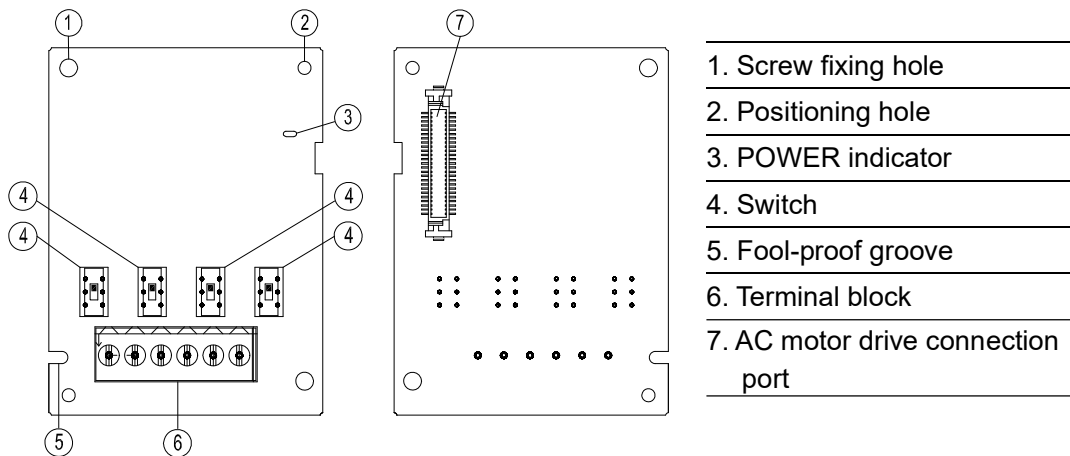

8-6-2 Terminal Specification

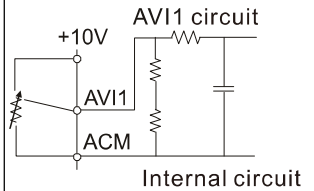
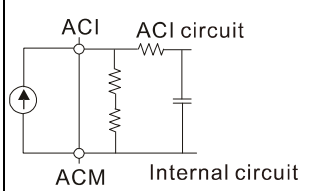
	Terminals	Descriptions	
Analog I/O Extension Card	AI10, AI11	<p>Refer to Pr.14-00–Pr.14-01 for function selection (input), and Pr.14-18–Pr.14-19 for mode selection.</p> <p>There are two sets of AI port, SSW3 (AI10) and SSW4 (AI11), which can be switched to Voltage or Current mode.</p> <p>Voltage mode: Input 0–10 V</p> <p>Current mode: Input 0–20 mA / 4–20 mA</p>	
		<p>Analog voltage frequency command</p> 	<p>Impedance: 20 kΩ</p> <p>Range: 0–10 V = 0–Max. Output Frequency (Pr.01-00)</p> <p>Switch: AI10 / AI11 Switch, default 0–10 V</p>
		<p>Analog current frequency command</p> 	<p>Impedance: 250 Ω</p> <p>Range: 0–20 mA / 4–20 mA = 0–Max. Output Frequency (Pr.01-00)</p> <p>Switch: AI10 / AI11 Switch, default 0–10 V</p>

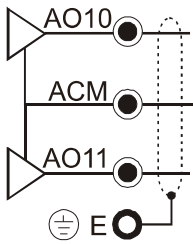
	<p>AO10, AO11</p>	<p>Refer to Pr.14-12–Pr.14-13 for function selection (output), and Pr.14-36–Pr.14-37 for mode selection.</p> <p>There are two sets of AO port, SSW1 (AO10) and SSW2 (AO11), which can be switched to Voltage or Current mode.</p> <p>Voltage mode: Output 0–10 V</p> <p>Current mode: Output 0–20 mA / 4–20 mA</p> <p>Multi-function analog output</p> 	<p>AVO:</p> <p>0–10 V Max. output current 2 mA, Max. load 5 kΩ</p> <p>Output current: 2 mA max</p> <p>Resolution: 0–10 V corresponds to Max. operation frequency</p> <p>Switch: AO10 / AO11 Switch, default 0–10 V</p> <hr/> <p>ACO:</p> <p>0–20 mA Max. Load 500 Ω</p> <p>Output current: 20 mA max</p> <p>Resolution: 0–20 mA / 4–20 mA corresponds to Max. operation frequency</p> <p>Switch: AO10 / AO11 Switch, default 0–10 V</p>
	<p>ACM</p>	<p>Analog Signal Common</p>	<p>Common for analog terminals</p>

8-7 EMC-PG01L / EMC-PG02L -- PG card (Line driver)

8-7-1 Terminal description

Set by Pr.10-00–10-02, Pr.10-16–10-18

Terminals		Descriptions
PG1	VP	Output voltage for power: +5 V / +12 V \pm 5% (use FSW3 to switch +5V / +12 V) Max. output current: 200 mA
	DCM	Common for power and signal
	A1, /A1, B1, /B1, Z1, /Z1	Encoder input signal (Line Driver or Open Collector) Open Collector input voltage: +5 – +24V (Note 1) It can be single-phase or two-phase input. EMC-PG01L: Max. input frequency: 300 kHz EMC-PG02L: Max. input frequency: 30 kHz (Note 2)
PG2	A2, /A2, B2, /B2	Pulse Input signal (Line Driver or Open Collector) Open Collector input voltage: +5 – +24V (Note1) It can be single-phase or two-phase input. EMC-PG01L: Max. input frequency: 300 kHz EMC-PG02L: Max. input frequency: 30 kHz (Note 2)
PG OUT	AO, /AO, BO, /BO, ZO, /ZO, SG	PG Card Output signals. It has division frequency function: 1–255 times Max. output voltage for Line driver: 5 V _{DC} Max. output current: 15 mA EMC-PG01L Max. output frequency: 300 kHz EMC-PG02L Max. output frequency: 30 kHz SG is the GND of PG card. It is also the GND of position machine or PLC to make the output signal to be the common pivot point.

Note 1: Open Collector application, input current 5–15 mA to each set then each set needs one pull-up resistor.

If input voltage of open collector is 24 V, the power of encoder needs to be connected externally.

Please refer to diagram 2 of PG1.

5V	Recommended pull-up resistor: above 100–220 Ω , 1/2W
12V	Recommended pull-up resistor: above 510 Ω –1.35 k Ω , 1/2W
24V	Recommended pull-up resistor: above 1.8k–3.3 k Ω , 1/2W

Note 2: If the required bandwidth is not over 30 kHz at the application, it is recommended to use

EMC-PG02O/L (bandwidth 30 kHz) to avoid interference.

PG1 card wiring diagram (the image 1 and 2 below are wiring diagrams of Open Collector encoder)

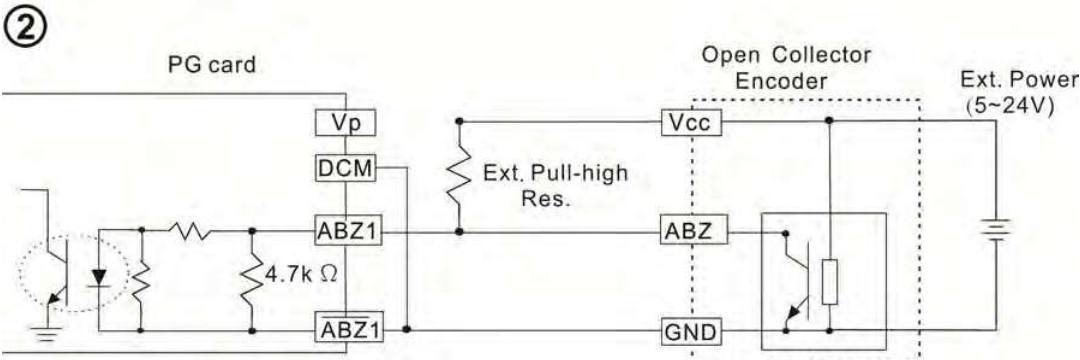
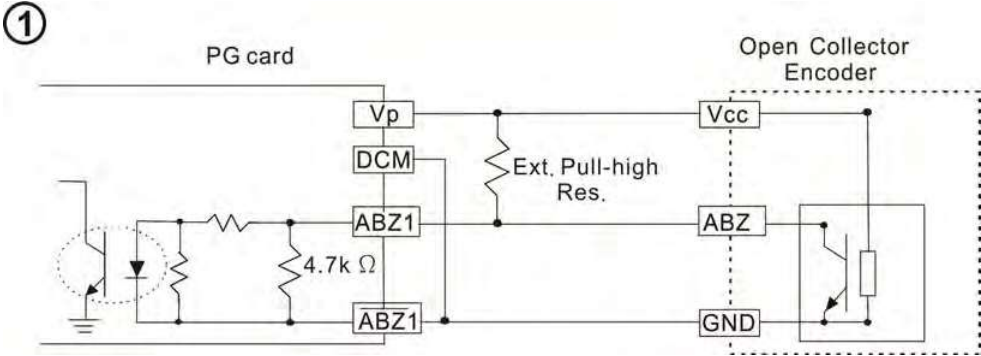

PG2 Wiring Diagram

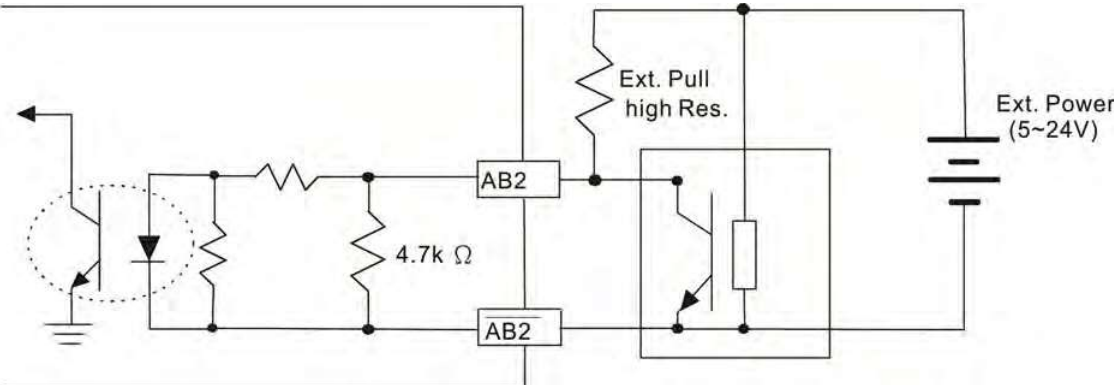

8-7-2 EMC-PG01L / EMC-PG02L Wiring Diagram

- ☑ Use a shielded cable to prevent interference. Do not run control wires parallel to any high voltage AC power line (200 V_{AC} and above).
- ☑ Recommended wire size: 0.2–0.75 mm² [24–18 AWG].
- ☑ Cable length: Single-phase input, less than 30m / two-phase input, less than 100 m

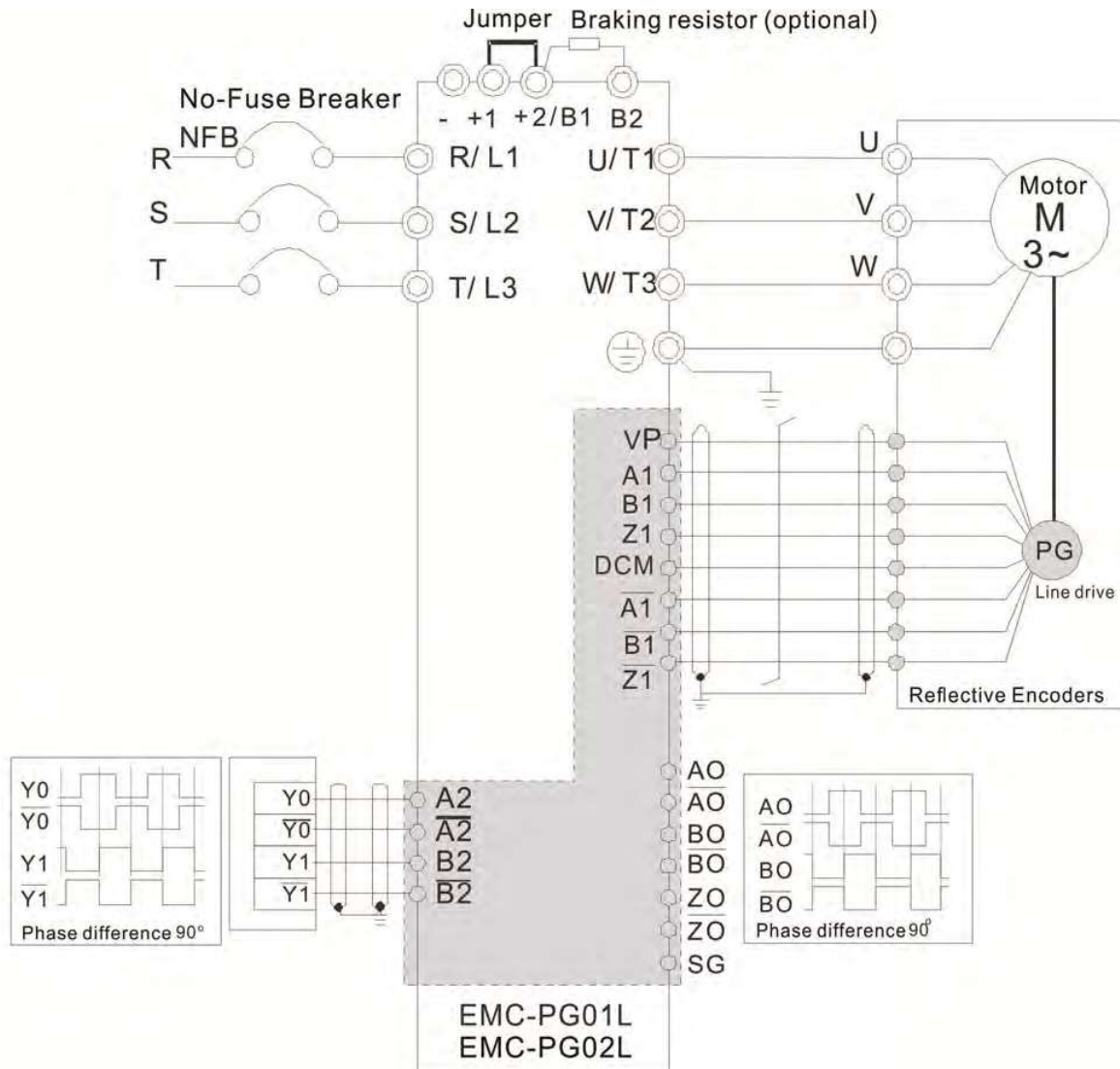

8-8 EMC-PG010 / EMC-PG020 -- PG card (Open collector)

8-8-1 Terminal descriptions

Set by Pr.10-00–10-02, Pr.10-16–10-18

Terminals		Descriptions
PG1	VP	Output voltage for power: +5V/+12V±5% (use FSW3 to switch +5V/+12V) Max. output current: 200 mA
	DCM	Common for power and signal
	A1, /A1, B1, /B1, Z1, /Z1	Encoder Input signal (Line Driver or Open Collector) Open Collector Input Voltage: +5V – +24V (Note 1) It can be single-phase or two-phase input. EMC-PG010 Max. input frequency: 300 kHz EMC-PG020 Max. input frequency: 30 kHz (Note 2)
PG2	A2, /A2, B2, /B2	Pulse Input Signal (Line Driver or Open Collector) Open Collector Input Voltage: +5 – +24V (Note 1) It can be single-phase or two-phase input. EMC-PG010 Max. input frequency: 300 kHz EMC-PG020 Max. input frequency: 30 kHz (Note 2)
PG OUT	V+, V+	Needs external power source for PG OUT circuit. Input voltage of power: +7V – +24V
	V-	Input voltage for the negative side
	A/O, B/O, Z/O	PG Card Output signals has division frequency function: 1–255 times. On the open collector's output signal, add a high-pull resistor on the external power V+ – V- (e.g. power of PLC) to prevent the interference of the receiving signal. Max. [Three pull-up resistor are included in the package (1.8 kΩ / 1W)] (Note 1) EMC-PG010 Max. input frequency: 300 kHz EMC-PG020 Max. input frequency: 30 kHz (Note 2)

Note 1: Open Collector application, input current 5–15mA to each set then each set needs one pull-up resistor.

If input voltage of open collector is 24V, the power of encoder needs to be connected externally.

Please refer to diagram 2 of PG1.

5V	Recommended pull-up resistor: above 100–220 Ω, 1/2W
12V	Recommended pull-up resistor: above 510Ω–1.35 kΩ, 1/2W
24V	Recommended pull-up resistor: above 1.8k–3.3 kΩ, 1/2W

Note 2: If the required bandwidth is not over 30 kHz at the application, it is recommended to use

EMC-PG020/L (bandwidth 30 kHz) to avoid interference.

PG1 card wiring diagram (the image 1 and 2 below are wiring diagrams of Open Collector encoder)

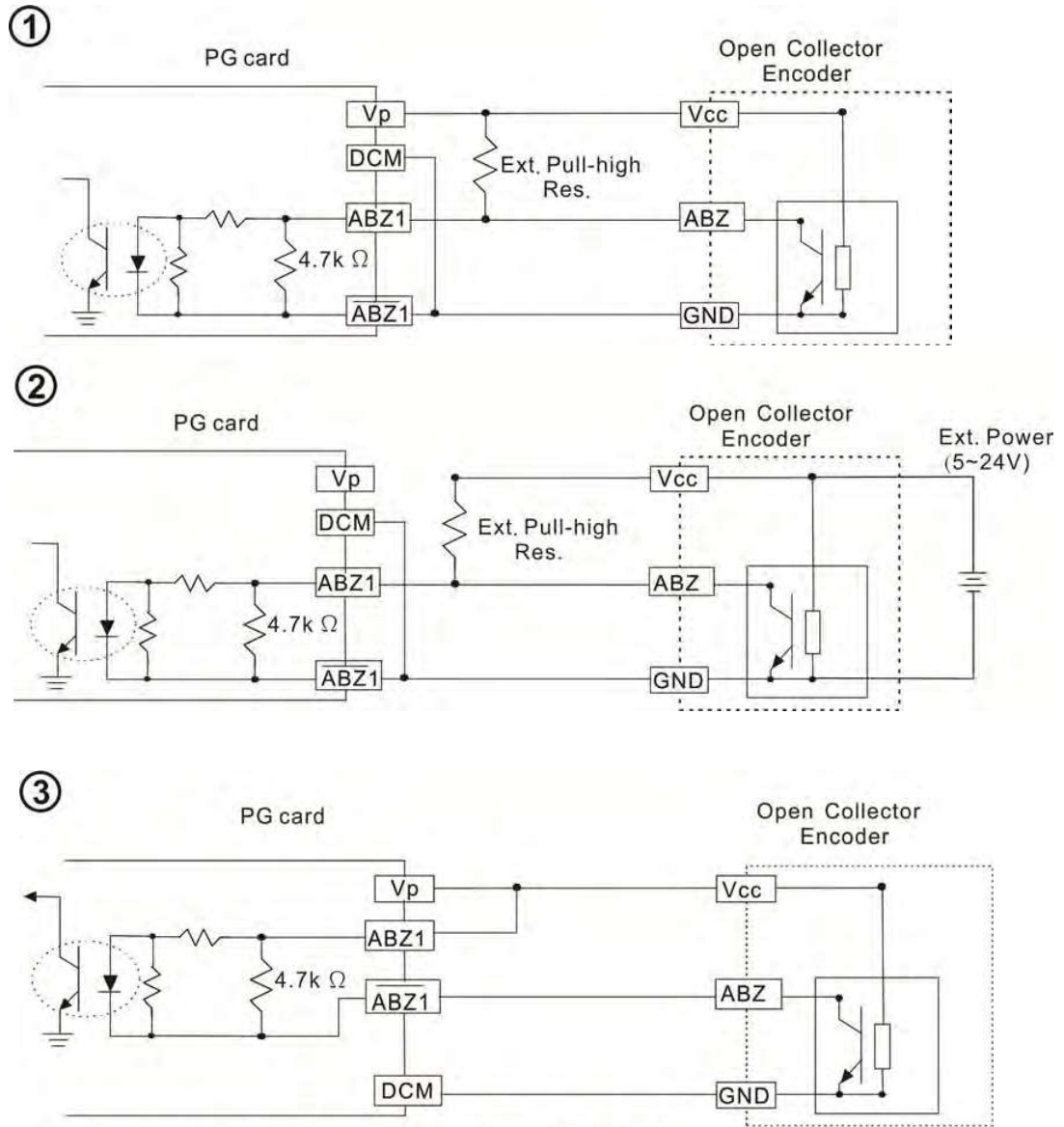

When wiring in this way, if there is a signal on EMC-PG010's A1, B1 and Z1, LED lights is OFF.

If A1, B1 and Z1 have no signals, LED lights is ON.

PG2 Wiring Diagram

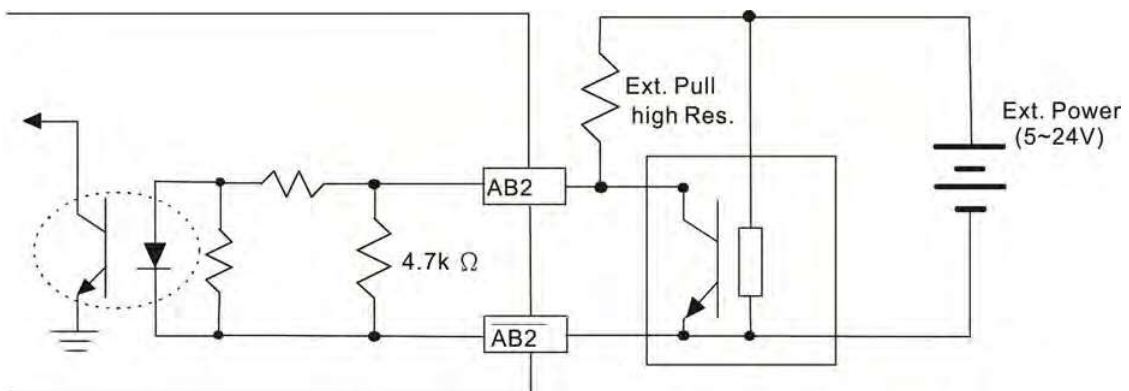

8-8-2 EMC-PG010 / EMC-PG020 Wiring Diagram

- ☑ Use a shielded cable to prevent interference. Do not run control wires parallel to any high voltage AC power line (200 V_{AC} and above).
- ☑ Recommended wire size 0.2–0.75 mm² [24–18 AWG].
- ☑ Cable length: Single-phase input, less than 30m / two-phase input, less than 100 m

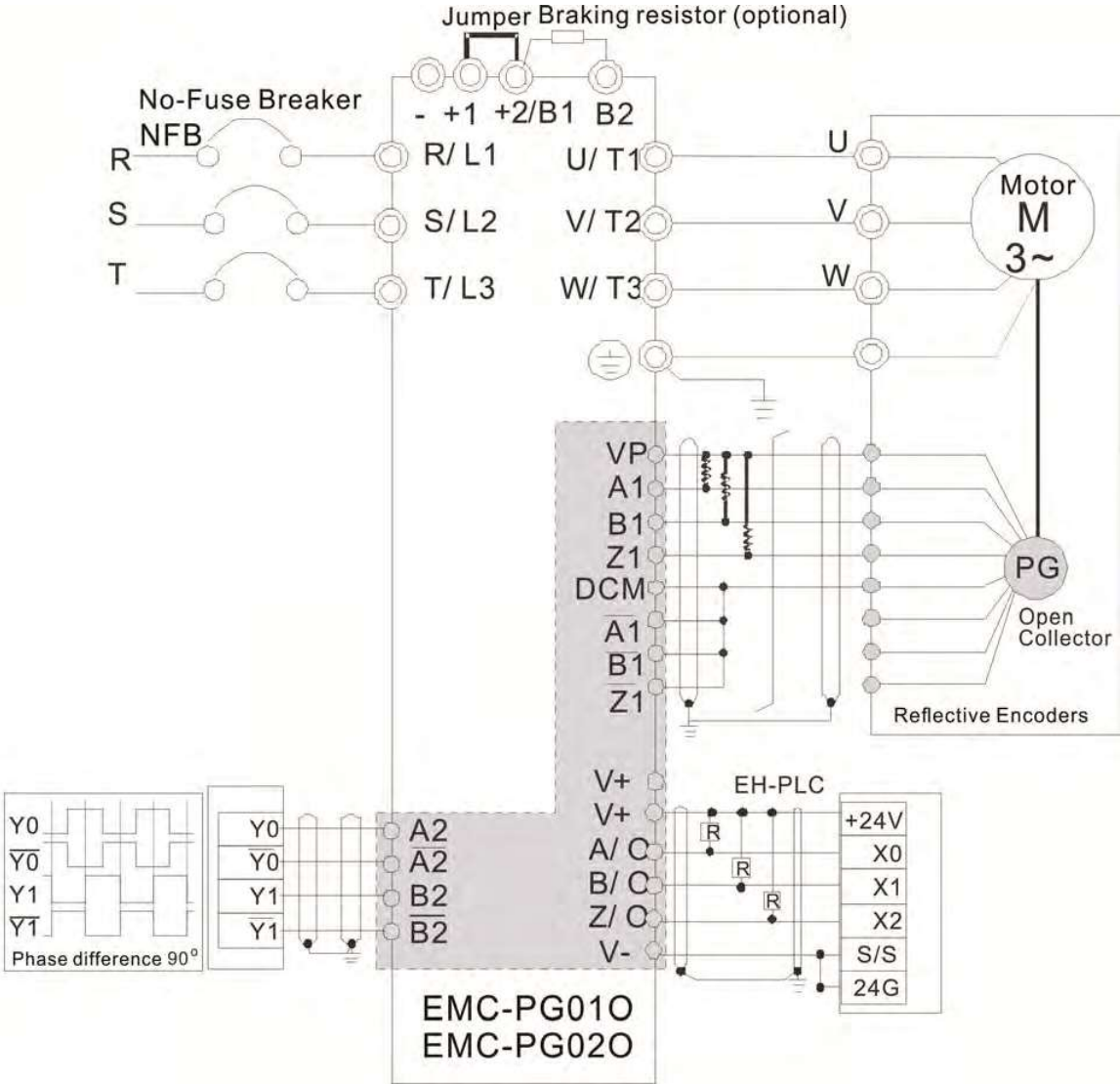

8-9 EMC-PG01U / EMC-PG02U

-- PG card (ABZ Incremental encoder signal/ UVW Hall position signal input)

1. FSW1 **S**: Standard UVW Output Encoder; **D**: Delta Encoder
2. When using the Delta Encoder, wait for at least 250 ms after powering up to receive signals from UVW. If a running command is received before UVW signals finish, a PGF5 error message will be given. So wait for 250 ms before sending a running command.
3. EMC-PG02U has encoder disconnection detection function.

8-9-1 Terminal descriptions

Set by Pr.10-00–10-02, Pr.10-16–10-18

Terminals		Descriptions
PG1	VP	Output voltage for power: +5V / +12V \pm 5% (use FSW3 to switch +5V / +12V) Max. output current: 200 mA
	DCM	Common for power and signal
	A1, /A1, B1, /B1, Z1, /Z1	Encoder input signal (Line Driver) It can be single-phase or two-phase input. Max. output frequency: 300 kHz
	U1, /U1, V1, /V1, W1, /W1	Encoder input signal
PG2	A2, /A2, B2, /B2	Pulse Input signal (Line Driver or Open Collector) Open Collector Input Voltage: +5 – +24V (Note1) It can be single-phase or two-phase input. Max. output frequency: 300 kHz.
PG OUT	AO, /AO, BO, /BO, ZO, /ZO, SG	PG Card Output signals. It has division frequency function: 1–255 times Max. output voltage for Line driver: 5 V _{DC} Max. output current: 15 mA Max. output frequency: 300 kHz SG is the GND of PG card. It is also the GND of position machine or PLC to make the output signal to be the common pivot point.

Note 1: Open Collector application, input current 5–15 mA to each set then each set needs one pull-up resistor.

5V	Recommended pull-up resistor: above 100–220 Ω , 1/2W
12V	Recommended pull-up resistor: above 510 Ω –1.35 k Ω , 1/2W
24V	Recommended pull-up resistor: above 1.8k–3.3 k Ω , 1/2W

PG2 Wiring Diagram

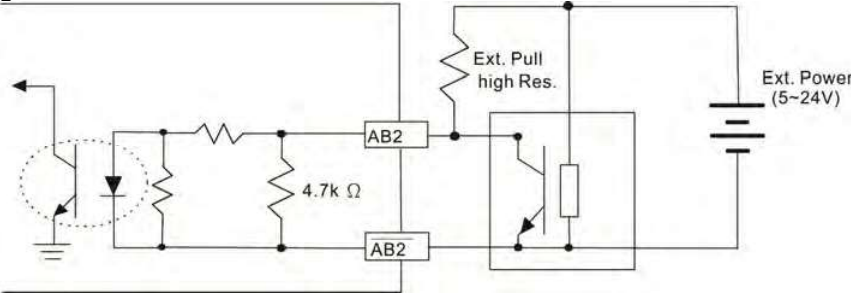

8-9-2 EMC-PG01U / EMC-PG02U Wiring Diagram

- ☑ Use a shielded cable to prevent interference. Do not run control wires parallel to any high voltage AC power line (200 V_{AC} and above).
- ☑ Recommended wire size 0.2–0.75 mm² [24–18 AWG].
- ☑ Cable length: Single-phase input, less than 30 m / two-phase input, less than 100 m

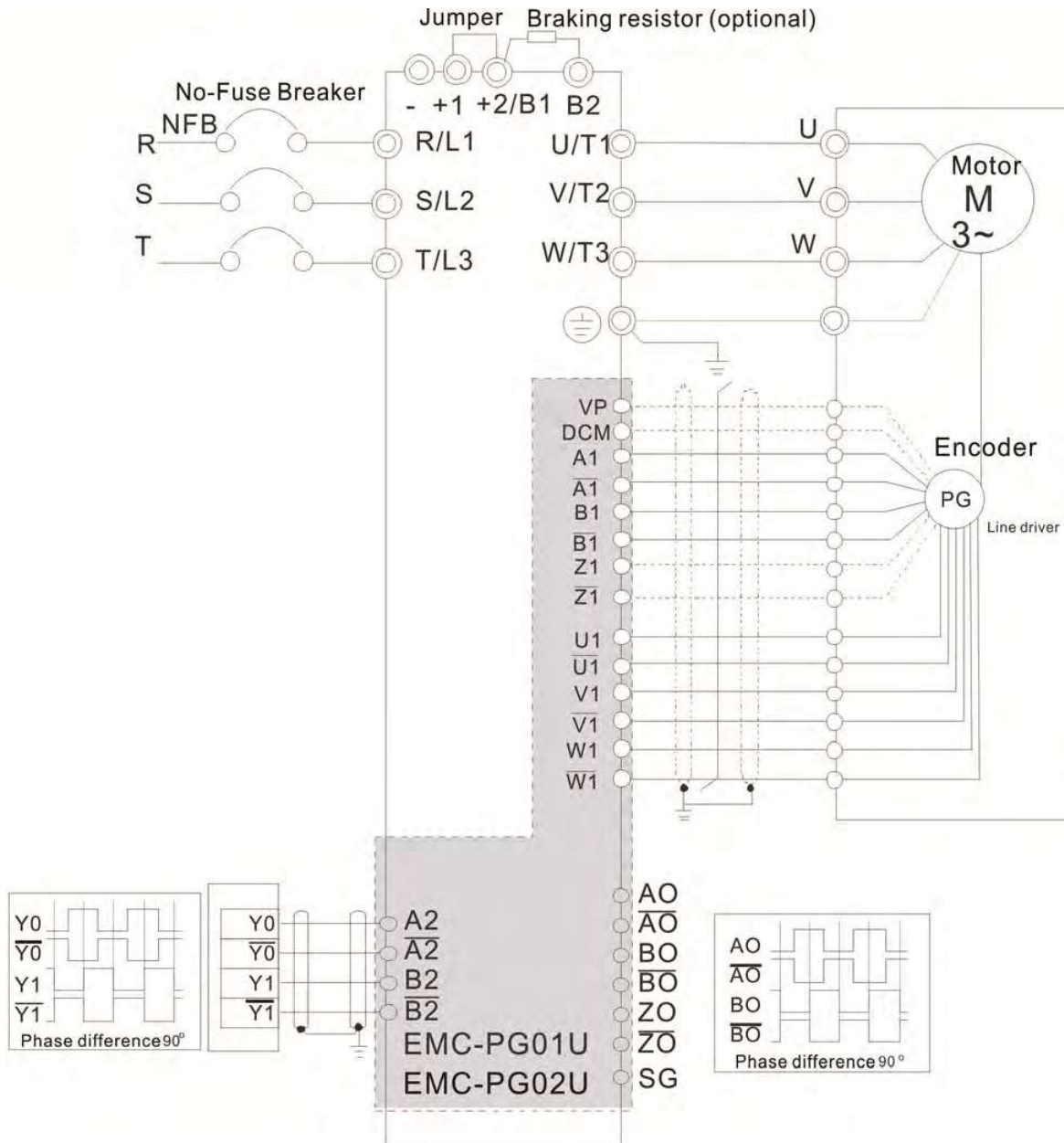

8-10 EMC-PG01R -- PG card (Resolver)

8-10-1 Terminal Descriptions

Set by Pr.10-00–10-02 and Pr.10-30 Resolver. (Pr.10-00=3, Pr.10-01=1024)

Terminals		Descriptions
PG1	R1- R2	Resolver Output Power 7 Vrms, 10 kHz
	S1, /S3, S2, /S4,	Resolver Input Signal (S2, /S4=Sin; S1, /S3=Cos) 3.5±0.175 Vrms, 10 kHz
PG2	A2, /A2, B2, /B2	Pulse Input signal (Line Driver or Open Collector) Open Collector Input Voltage: +5 – +24V (Note1) It can be single-phase or two-phase input. Max. output frequency: 300 kHz
PG OUT	AO, /AO, BO, /BO, ZO, /ZO, SG,	PG Card Output signals. It has division frequency function: 1–255 times Max. output voltage for Line driver: 5 V _{DC} Max. output current: 15 mA Max. output frequency: 300 kHz SG is the GND of PG card. It is also the GND of position machine or PLC to make the output signal to be the common pivot point.

Note 1: Open Collector application, input current 5–15 mA to each set then each set needs one pull-up resistor.

5V	Recommended pull-up resistor: above 100–220 Ω, 1/2W
12V	Recommended pull-up resistor: above 510Ω–1.35 kΩ, 1/2W
24V	Recommended pull-up resistor: above 1.8k–3.3 kΩ, 1/2W

PG2 Wiring Diagram

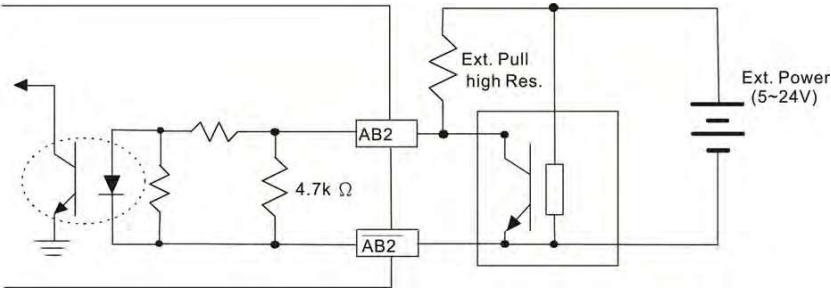

- DOS (Degradation of Signal)** : If the amplitude of the sine wave input of the S1-/S3/ S2-/S4 is lower than or higher than the encoder IC's specification, a red light will be on. The possible reasons which cause this problem are the following.

 1. The turns ratio of the resolver encoder is not 1:0.5 which makes the sine wave input of the S1-/S3/S2-/S4 not equal to 3.5±0.175 Vrms.
 2. While motor is running, motor creates common mode noise which makes accumulated voltage to be more than 3.5±0.175 Vrms
- LOT (Loss of Tracking)**: Compare the angle of S1-/S3/S2-/S4 sine wave input to the R1-R2 cosine wave. If their difference is more than 5 degree, a red light will be on. Here are the possible reasons why that happens:

 1. The output frequency of the PG card is incorrect.
 2. The specification of Resolver's encoder is not 10 kHz
 3. The motor creates common mode noise while it is running. That causes a big difference, while the motor is rotating, between main winding's cosine wave angle and the sine wave angle of second and third windings.

8-10-2 EMC-PG01R Wiring Diagram

- ☑ Use a shielded cable to prevent interference. Do not run control wires parallel to any high voltage AC power line (200 V_{AC} and above).
- ☑ Recommended wire size 0.2–0.75 mm² [24–18 AWG].
- ☑ Cable length: PG1 input, less than 30m; PG2 single-phase input, less than 30 m / two-phase input, less than 100 m

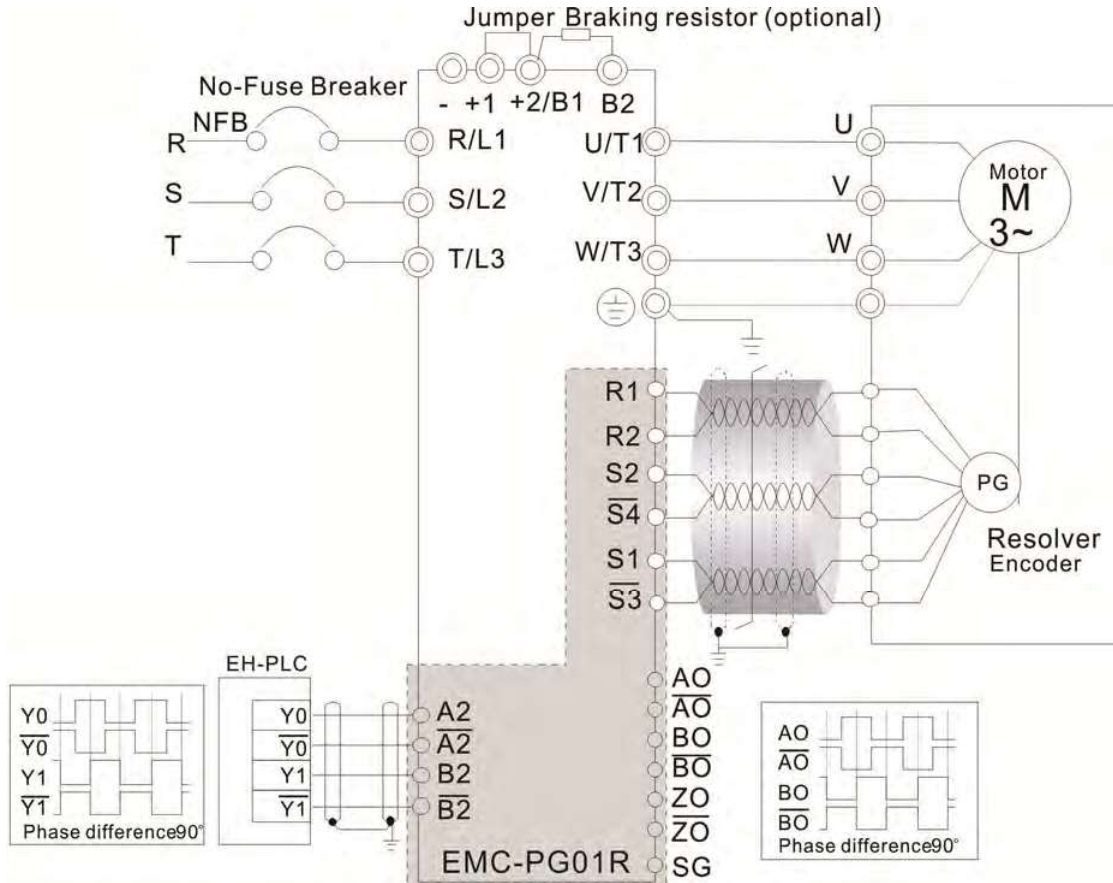

8-11 EMC-PG01H – PG card (Resolver)

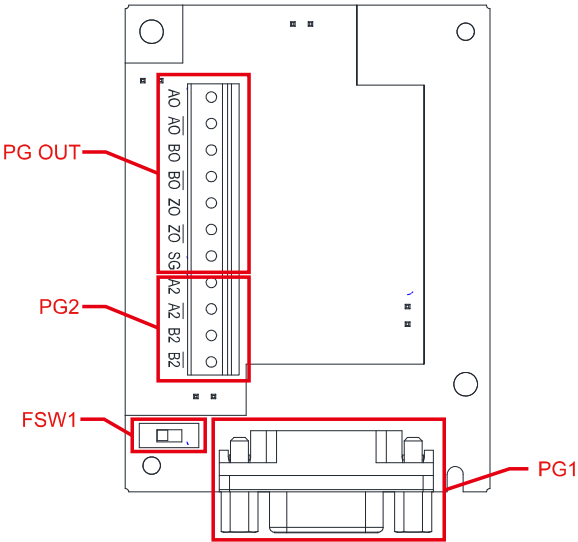



1. The PG1 at input side is SinCos signal of 1 Vpp, and the bandwidth is 600 kHz.
2. The principle of operation for a SinCos encoder is similar to a square-wave encoder, but use SinCos signal instead.
3. The pulse unit of SinCos encoder is ppr, 1024 ppr means 1024 SinCos signals per revolution with single phase.

8-11-1 Terminal Descriptions

Set by Pr.10-00–10-03 and Pr.10-16–10-18.

Terminals		Descriptions	
PG1	VP	Power output voltage: +5V / +8V ± 5% (+5V / +8V decided by FSW1) Max. output current: 200 mA	
	DCM	Digital control / Frequency signal common	
	A+, A-, B+, B-, R+, R-	Encoder wave difference signal input (Incremental signal) Max. output frequency: 600 kHz	
C+, C-, D+, D-	Encoder wave difference signal input (Absolute signal)		
PG2	A2, /A2, B2, /B2	Pulse Input signal (Line Driver or Open Collector) Open Collector Input Voltage: +5 – +24V (Note1) It can be single-phase or two-phase input. Max. output frequency: 300 kHz	

PG OUT	AO, /AO, BO, /BO, ZO, /ZO, SG	<p>PG Card Output signals. It has division frequency function: 1–255 times</p> <p>Max. output voltage for Line driver: 5 V_{DC}</p> <p>Max. output current: 15 mA</p> <p>Max. output frequency: 600 kHz ± 5%</p> <p>SG is the GND of PG card. It is also the GND of position machine or PLC to make the output signal to be the common pivot point.</p>
FSW1		<p>Use FSW1 to switch the power of VP: +5V / +8V</p> <div style="display: flex; justify-content: space-around; align-items: center;"> <div style="text-align: center;">  +8V </div> <div style="text-align: center;">  +5V </div> </div>

Note 1: Open Collector application, input current 5–15 mA to each set then each set needs one pull-up resistor.

If input voltage of open collector is 24V, the power of encoder needs to be connected externally. Please refer to diagram 2 of PG2.

5V	Recommended pull-up resistor: above 100–220 Ω, 1/2W
12V	Recommended pull-up resistor: above 510Ω–1.35 kΩ, 1/2W
24V	Recommended pull-up resistor: above 1.8k–3.3 kΩ, 1/2W

PG1 Terminal descriptions (15pin D-SUB female connector)

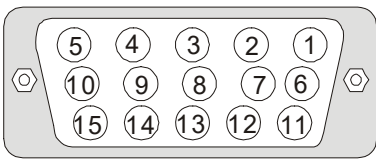

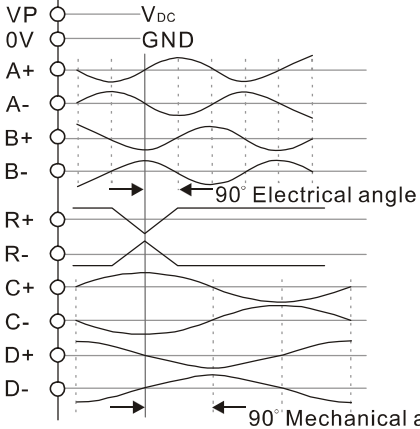

No.	Terminals	No.	Terminals
1	B-	9	VP
2	NC	10	C+
3	R+	11	C-
4	R-	12	D+
5	A+	13	D-
6	A-	14	NC
7	DCM	15	NC
8	B+		

PG2 wiring diagram

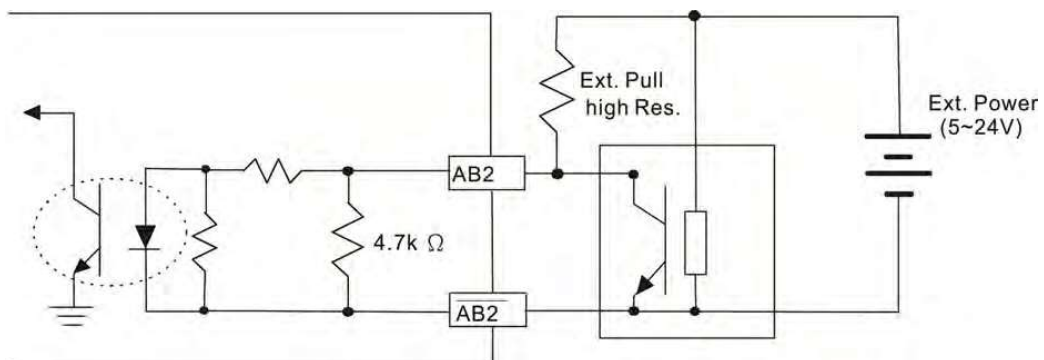

8-11-2 EMC-PG01H Wiring Diagram

- ☑ Use a shielded cable to prevent interference. Do not run control wires parallel to any high voltage AC power line (200 V_{AC} and above).
- ☑ Recommended wire size 0.2–0.75 mm² [24–18 AWG].
- ☑ Cable length: PG1 input, less than 10 m; PG2 single-phase input, less than 30 m / two-phase input, less than 100 m

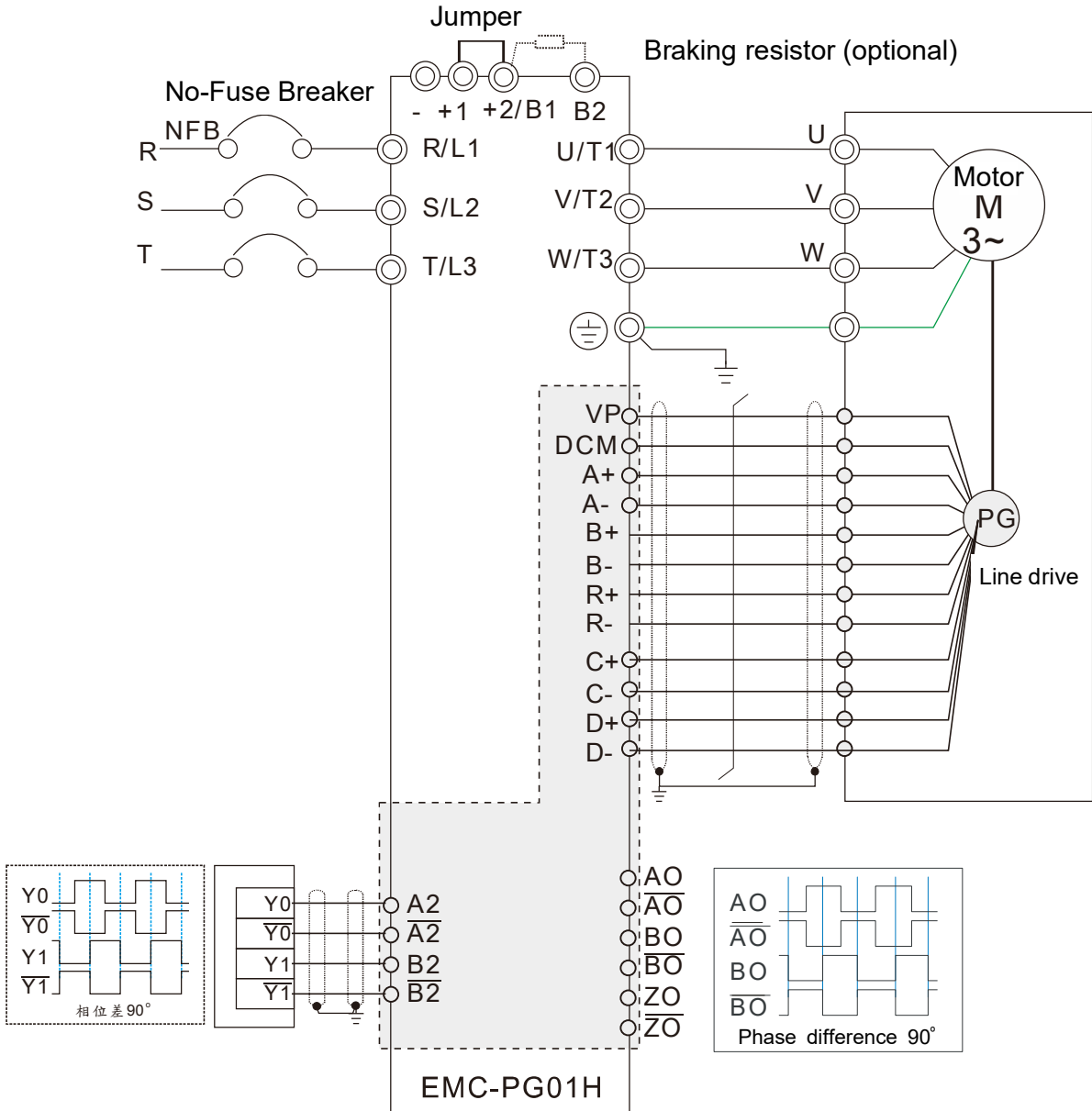

8-12 CMC-PD01 -- Communication card, PROFIBUS DP

8-12-1 Features

1. Supports PZD control data exchange.
2. Supports PKW access AC motor drive parameters.
3. Supports user diagnosis function.
4. Auto-detects baud rates; supports a Max. 12 Mbps.

8-12-2 Product Profile

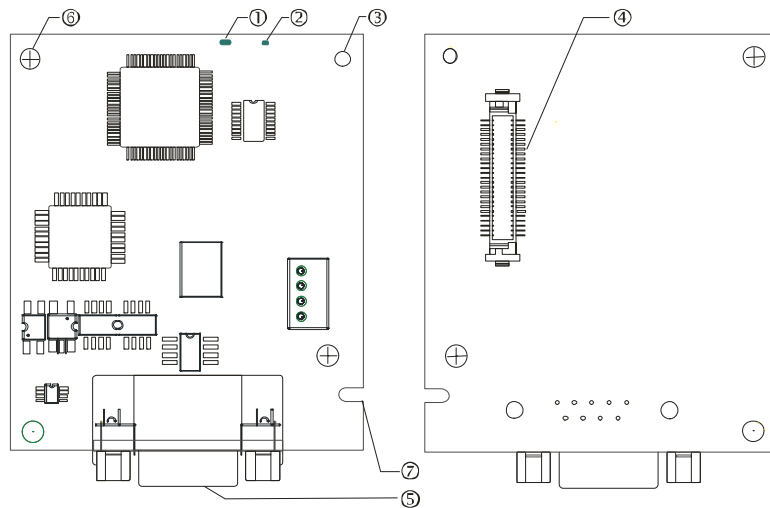

-
1. NET indicator
 2. POWER indicator
 3. Positioning hole
 4. AC motor drive connection port
 5. PROFIBUS DP connection port
 6. Screw fixing hole
 7. Fool-proof groove
-

8-12-3 Specifications

PROFIBUS DP Connector

Interface	DB9 connector
Transmission method	High-speed RS-485
Transmission cable	Shielded twisted pair cable
Electrical isolation	500 V _{DC}

Communication

Message type	Cyclic data exchange
Module name	CMC-PD01
GSD document	DELA08DB.GSD
Company ID	08DB (HEX)
Serial transmission speed supported (auto-detection)	9.6 Kbps; 19.2 Kbps; 93.75 Kbps; 187.5 Kbps; 500 Kbps; 1.5 Mbps; 3 Mbps; 6 Mbps; 12 Mbps (bit per second)

Electrical Specification

Power supply voltage	5 V _{DC} (supplied by the AC motor drive)
Insulation voltage	500 V _{DC}
Power consumption	1 W
Weight	28 g

Environment

Noise immunity	ESD (IEC 61800-5-1, IEC 61000-4-2) EFT (IEC 61800-5-1, IEC 61000-4-4) Surge Teat (IEC 61800-5-1, IEC 61000-4-5) Conducted Susceptibility Test (IEC 61800-5-1, IEC 61000-4-6)
Operation /storage	Operation: -10°C – 50°C (temperature), 90% (humidity) Storage: -25°C – 70°C (temperature), 95% (humidity)
Shock / vibration resistance	International standards: IEC61131-2, IEC60068-2-6 (TEST Fc) / IEC61131-2 & IEC 60068-2-27 (TEST Ea)

8-12-4 Installation

PROFIBUS DP Connector

PIN	Signal	Definition
1	-	Not defined
2	-	Not defined
3	Rxd/Txd-P	Sending / receiving data P(B)
4	-	Not defined
5	DGND	Data reference ground
6	VP	Power voltage – positive
7	-	Not defined
8	Rxd/Txd-N	Sending/receiving data N(A)
9	-	Not defined

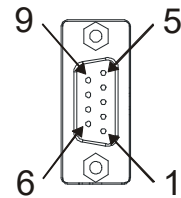

8-12-5 LED Indicator & Troubleshooting

There are 2 LED indicators on CMC-PD01: POWER LED and NET LED. POWER LED displays the status of the working power. NET LED displays the connection status of the communication.

POWER LED

LED status	Indication	Corrective Action
Green light on	Power supply in normal status.	--
Off	No power	Check if the connection between CMC-PD01 and AC motor drive is normal.

NET LED

LED status	Indication	Corrective Action
Green light on	Normal status	--
Red light on	CMC-PD01 is not connected to PROFIBUS DP bus.	Connect CMC-PD01 to PROFIBUS DP bus.
Red light flashes	Invalid PROFIBUS communication address	Set the PROFIBUS address of CMC-PD01 between 1 – 125 (decimal)
Orange light flashes	CMC-PD01 fails to communication with the AC motor drive.	Switch off the power and check whether CMC-PD01 is correctly and normally connected to AC motor drive.

8-13 CMC-DN01 -- Communication card, DeviceNet

8-13-1 Functions

1. Based on the high-speed communication interface of Delta HSSP protocol, able to conduct immediate control to AC motor drive.
2. Supports Group 2 only connection and polling I/O data exchange.
3. For I/O mapping, supports Max. 32 words of input and 32 words of output.
4. Supports EDS file configuration in DeviceNet configuration software.
5. Supports all baud rates on DeviceNet bus: 125 Kbps, 250 Kbps, 500 Kbps and extendable serial transmission speed mode.
6. Node address and serial transmission speed can be set up on AC motor drive.
7. Power supplied from AC motor drive.

8-13-2 Product Profile

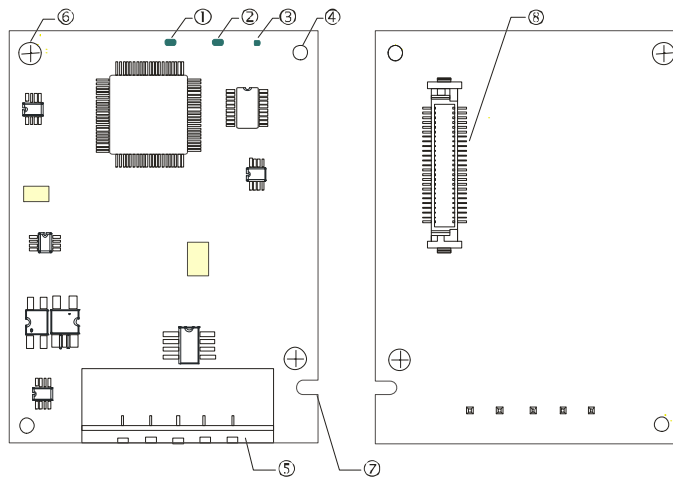

1. NS indicator
2. MS indicator
3. POWER indicator
4. Positioning hole
5. DeviceNet connection port
6. Screw fixing hole
7. Fool-proof groove
8. AC motor drive connection port

8-13-3 Specifications

DeviceNet Connector

Interface	5-PIN open removable connector of 5.08 mm PIN interval
Transmission method	CAN
Transmission cable	Shielded twisted pair cable (with 2 power cables)
Transmission speed	125 Kbps, 250 Kbps, 500 Kbps and extendable serial transmission speed mode
Network protocol	DeviceNet protocol

AC Motor Drive Connection Port

Interface	50 PIN communication terminal
Transmission method	SPI communication
Terminal function	1. Communicating with the AC motor drive 2. Transmitting power supply from the AC motor drive
Communication	Delta HSSP protocol

Electrical Specification

Power supply voltage	5 V _{DC} (supplied by the AC motor drive)
Insulation voltage	500 V _{DC}
Communication wire power consumption	0.85 W
Power consumption	1 W
Weight	23 g

Environment

Noise immunity	ESD (IEC 61800-5-1, IEC 61000-4-2) EFT (IEC 61800-5-1, IEC 61000-4-4) Surge Teat(IEC 61800-5-1, IEC 61000-4-5) Conducted Susceptibility Test (IEC 61800-5-1, IEC 61000-4-6)
Operation /storage	Operation: -10°C – 50°C (temperature), 90% (humidity) Storage: -25°C – 70°C (temperature), 95% (humidity)
Shock / vibration resistance	International standards: IEC61800-5-1, IEC60068-2-6 (TEST Fc) / IEC61800-5-1 & IEC60068-2-27 (TEST Ea)

8-13-4 Installation

DeviceNet Connector

PIN	Signal	Color	Definition
1	V+	Red	DC 24V
2	H	White	Signal+
3	S	-	Earth
4	L	Blue	Signal-
5	V-	Black	0V

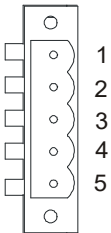

8-13-5 LED Indicator & Troubleshooting

There are three LED indicators on the CMC-DN01. POWER LED displays the status of power supply. MS LED and NS LED are dual-color LED, displaying the connection status of the communication and error messages.

POWER LED

LED status	Indication	Corrective Action
Off	Power supply in abnormal status.	Check the power supply of CMC-DN01.
Green light On	Power supply in normal status	--

NS LED

LED status	Indication	Corrective Action
Off	No power supply or CMC-DN01 does not pass the MAC ID test.	<ol style="list-style-type: none"> 1. Check the power of CMC-DN01 and see if the connection is normal. 2. Make sure at least one or more nodes are on the bus. 3. Check if the serial transmission speed of CMC-DN01 is the same as that of other nodes.
Green light flashes	CMC-DN01 is on-line but does not connect to the master.	<ol style="list-style-type: none"> 1. Configure CMC-DN01 to the scan list of the master. 2. Re-download the configured data to the master.
Green light on	CMC-DN01 is on-line and normally connects to the master	--
Red light flashes	CMC-DN01 is on-line, but I/O connection is timed-out.	<ol style="list-style-type: none"> 1. Check if the network connection is normal. 2. Check if the master operates normally.
Red light on	<ol style="list-style-type: none"> 1. The communication is down. 2. MAC ID test failure. 3. No network power supply. 4. CMC-DN01 is off-line. 	<ol style="list-style-type: none"> 1. Make sure all the MAC IDs on the network are not repeated. 2. Check if the network installation is normal. 3. Check if the baud rate of CMC-DN01 the same as that of other nodes. 4. Check if the node address of CMC-DN01 is illegal. 5. Check if the network power supply is normal.

MS LED

LED status	Indication	Corrective Action
Off	No power supply or being off-line	Check the power supply of CMC-DN01 and see if the connection is normal.
Green light flashes	Waiting for I/O data	Switch the master PLC to RUN status
Green light on	I/O data is normal	--
Red light flashes	Mapping error	<ol style="list-style-type: none"> 1. Reset CMC-DN01 2. Re-power the AC motor drive
Red light on	Hardware error	<ol style="list-style-type: none"> 1. See the fault codes displayed on the AC motor drive. 2. Send back to the factory for repair if necessary.
Orange light flashes	CMC-DN01 is establishing connection with the AC motor drive.	If the flashing lasts for a long time, turn off the power and check if CMC-DN01 and the AC motor drive are correctly installed and normally connected to each other.

8-14 CMC-EIP01 -- Communication card, EtherNet/IP

8-14-1 Features

1. Supports Modbus TCP and Ethernet/IP protocol
2. User-defined corresponding parameters (use with EIP V.1.06)
3. IP filter simple firewall function
4. MDI/MDI-X auto-detect
5. Baud rate: 10/100Mbps auto-detect

8-14-2 Product Profile

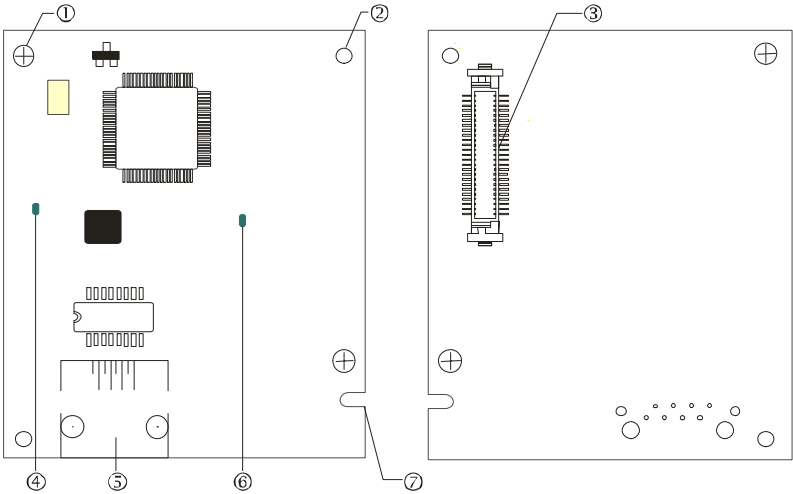

[Figure1]

- 1. Screw fixing hole
- 2. Positioning hole
- 3. AC motor drive connection port
- 4. LINK indicator
- 5. RJ45 connection port
- 6. POWER indicator
- 7. Alignment groove

8-14-3 Specifications

Network Interface

Interface	RJ45 with Auto MDI/MDIX
Number of ports	1 Port
Transmission method	IEEE 802.3, IEEE 802.3u
Transmission cable	Category 5e shielding 100M
Transmission speed	10/100 Mbps Auto-Detect
Network protocol	ICMP, IP, TCP, UDP, DHCP, HTTP, SMTP, Modbus over TCP/IP, EtherNet/IP, Delta Configuration

Electrical Specification

Weight	25g
Insulation voltage	500V _{DC}
Power consumption	0.8W
Power supply voltage	5V _{DC} (provided by VFD-C2000 Plus)

Environment

Noise immunity	ESD (IEC 61800-5-1, IEC 61000-4-2) EFT (IEC 61800-5-1, IEC 61000-4-4) Surge Test (IEC 61800-5-1, IEC 61000-4-5) Conducted Susceptibility Test (IEC 61800-5-1, IEC 61000-4-6)
Operation/storage	Operation: -10°C–50°C (temperature), 90% (humidity) Storage: -25°C–70°C (temperature), 95% (humidity)
Vibration/shock immunity	International standards: IEC 61800-5-1, IEC 60068-2-6/IEC 61800-5-1, IEC 60068-2-27

8-14-4 Installation

Connecting CMC-EIP01 to Network

1. Turn off the power of the drive.
2. Open the cover of the AC motor drive.
3. Connect a CAT-5e network cable to the RJ45 port on the CMC-EIP01 (See Figure 2).

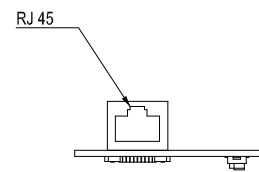

[Figure 2]

RJ45 PIN Definition

PIN	Signal	Definition
1	Tx+	Positive pole for data transmission
2	Tx-	Negative pole for data transmission
3	Rx+	Positive pole for data reception
4	--	N/C

PIN	Signal	Definition
5	--	N/C
6	Rx-	Negative pole for data reception
7	--	N/C
8	--	N/C

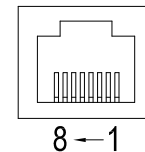

8-14-5 C2000 Plus Communication Parameter Settings for Connecting to Ethernet

When the C2000 Plus is connected to an Ethernet network, please set up the communication parameters for it according to the table below. The Ethernet master is only able to reads and writes the frequency words and control word of C2000 Plus after the communication parameters are set.

Parameters	Function	Current Setting Value	Description
00-20	Master frequency command setting	8	The frequency command is controlled by communication card.
00-21	Source of operation command setting	5	The operation command is controlled by communication card.
09-30	Communication decoding method	0	The decoding method for Delta AC motor drive
09-75	IP configuration	0	0: Static IP 1: Dynamic IP (DHCP)
09-76	IP address -1	192	IP address <u>192</u> .168.1.5
09-77	IP address -2	168	IP address 192. <u>168</u> .1.5
09-78	IP address -3	1	IP address 192.168. <u>1</u> .5

Parameters	Function	Current Setting Value	Description
09-79	IP address -4	5	IP address 192.168.1. <u>5</u>
09-80	Netmask -1	255	Netmask <u>255.255.255.0</u>
09-81	Netmask -2	255	Netmask 255. <u>255.255.0</u>
09-82	Netmask -3	255	Netmask 255.255. <u>255.0</u>
09-83	Netmask -4	0	Netmask 255.255.255. <u>0</u>
09-84	Default gateway -1	192	Default gateway <u>192.168.1.1</u>
09-85	Default gateway -2	168	Default gateway 192. <u>168.1.1</u>
09-86	Default gateway -3	1	Default gateway 192.168. <u>1.1</u>
09-87	Default gateway -4	1	Default gateway 192.168.1. <u>1</u>

8-14-6 LED Indicator & Troubleshooting

There are two LED indicators on the CMC-EIP01. The POWER LED displays the status of power supply, and the LINK LED displays the connection status of the communication.

LED Indicators

LED	Status	Indication	Corrective Action	
POWER	Green	On	Power supply in normal status	--
		Off	No power supply	Check the power supply.
LINK	Green	On	Network connection in normal status	--
		Flashin	Network in operation	--
		Off	Network not connected	Check if the network cable is connected.

Troubleshooting

Abnormality	Cause	Corrective Action
POWER LED off	The AC motor drive not powered	Check the power of the AC motor drive, and see if the power supply is normal.
	The CMC-EIP01 not connected to the AC motor drive	Ensure that CMC-EIP01 is connected to the AC motor drive.
LINK LED off	The CMC-EIP01 not connected to network	Ensure that the network cable is correctly connected to network.
	Poor contact to RJ45 connector	Ensure that RJ45 connector is connected to Ethernet port.
Cannot find communication card	The CMC-EIP01 not connected to network	Ensure that CMC-EIP01 is connected to network.
	The PC and CMC-EIP01 in different networks and blocked by network firewall.	Search by IP or set up relevant settings by the AC motor drive keypad.
Cannot open CMC-EIP01 setup page	The CMC-EIP01 not connected to network	Ensure that CMC-EIP01 is connected to the network.
	Incorrect communication setting in DCISoft	Ensure that the communication setting in DCISoft is set to Ethernet.
	The PC and CMC-EIP01 in different networks and blocked by network firewall.	Set up with the AC motor drive keypad.

Abnormality	Cause	Corrective Action
The CMC-EIP01 setup page opens successfully but webpage monitoring is unavailable	Incorrect network setting in CMC-EIP01	Check if the network setting for CMC-EIP01 is correct. For the Intranet setting in your company, please consult your IT staff. For the Internet setting in your home, please refer to the network setting instruction provided by your ISP.
Cannot send e-mails	Incorrect network setting in CMC-EIP01	Check if the network setting for CMC-EIP01 is correct.
	Incorrect mail server setting	Please confirm the IP address for SMTP-Server.

8-15 CMC-EC01 -- Communication card, EtherCAT

8-15-1 Features

The EtherCAT of C2000 Plus currently provides standard control mode of CiA402 Velocity (Index 6060=2), but it is non-synchronous control mode. There is no need to turn on the DC (Distribute Clock) function when operating. However, if the DC function is required for using with synchronous products (e.g. ASDA-A2), the CMC-EC01 can still be used normally under this circumstances. The C2000 Plus supports the EtherCAT function with firmware version 3.05 and above. Please be attention to the firmware you use.

8-15-2 Product Profile

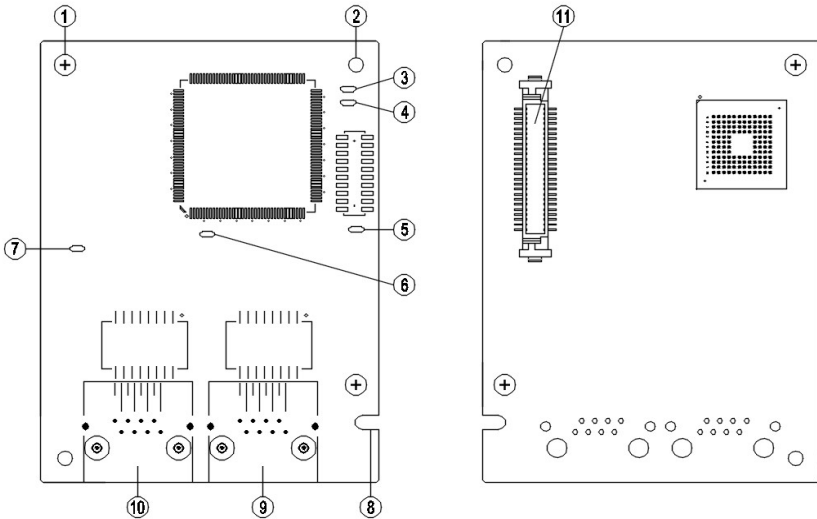

[Figure 1]

- 1. Screw fixing hole
- 2. Positioning hole
- 3. RUN indicator
- 4. ERR indicator
- 5. POWER indicator
- 6. OUT LINK indicator
- 7. IN LINK indicator
- 8. Fool-proof groove
- 9. RJ45 connection port
- 10. RJ45 connection port
- 11. Control board connection port

8-15-3 Specifications

Network Interface

Interface	RJ45
Number of ports	2 ports
Transmission method	IEEE802.3, IEEE802.3u
Transmission cable	Category 5e shielding 100 M
Transmission speed	10 / 100 Mbps Auto-Defect
Network protocol	EtherCAT

Electrical Specification

Power supply voltage	5 V _{DC}
Power consumption	0.8 W
Insulation voltage	500 V _{DC}
Weight (g)	27

Environment

Noise immunity	ESD (IEC 61800-5-1, IEC 61000-4-2) EFT (IEC 61800-5-1, IEC 61000-4-4) Surge Test (IEC 61800-5-1, IEC 61000-4-5) Conducted Susceptibility Test (IEC 61800-5-1, IEC 61000-4-6)
Operation	-10°C – 15°C (temperature), 90% (humidity)
Storage	-25°C – 70°C (temperature), 95% (humidity)
Vibration / shock immunity	International standard: IEC 61800-5-1, IEC 60068-2-6 / IEC 61800-5-1, IEC 60068-2-27

8-15-4 RJ45 PIN Definition

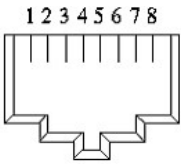
RJ45	PIN No.	Signal	Definition
	1	Tx+	Positive pole for data transmission
	2	Tx-	Negative pole for data transmission
	3	Rx+	Positive pole for data receiving
	4	--	N / C
	5	--	N / C
	6	Rx-	Negative pole for data receiving
	7	--	N / C
	8	--	N / C

8-15-5 Communication Parameters for C2000 Plus Connected to EtherCAT

When operating C2000 Plus via CMC-EC01, please set the control and operation command as controlled by communication card. When C2000 Plus is connected to EtherCAT network, please set up the communication parameters according to the table below.

Parameters	Set value (Dec)	Explanation
00-20	8	The frequency command is controlled by communication card.
00-21	5	The operation command is controlled by communication card.
09-60	6	Identification: when CMC-EC01 is connected, Pr.09-60 will show value 6 (EtherCAT Slave)
09-61	--	Version of communication card

8-15-6 LED Indicator

LED	Status	Indication	
POWER	Green	On	Power supply in normal status
		Off	No power supply
LINK	Green	On	Operate in normal status
		Flashes	Pre-operation (On / Off 200 ms)
			Operate in safe mode (On 200 ms / Off 1000 ms)
Off	Initial state		
ERROR	Red	Flashes	Basic configuration error (On / Off 200 ms)
			Status switching error (On 200 ms / Off 1000 ms)
			Times out (On 200 ms twice / Off 1000 ms)
		Off	No error

LED	Status	Indication	
IN LINK	Green	On	Network connection in normal status
		Flashes	Network in operation
		Off	Network not connected
OUT LINK	Green	On	Network connection in normal status
		Flashes	Network in operation
		Off	Network not connected

8-15-7 Network Connection

Because the packet delivery of EtherCAT has directional characteristics, the connection must be correct. The designed delivery direction of CMC-EC01 is left for IN / right for ON, the correct wiring is as below shown:

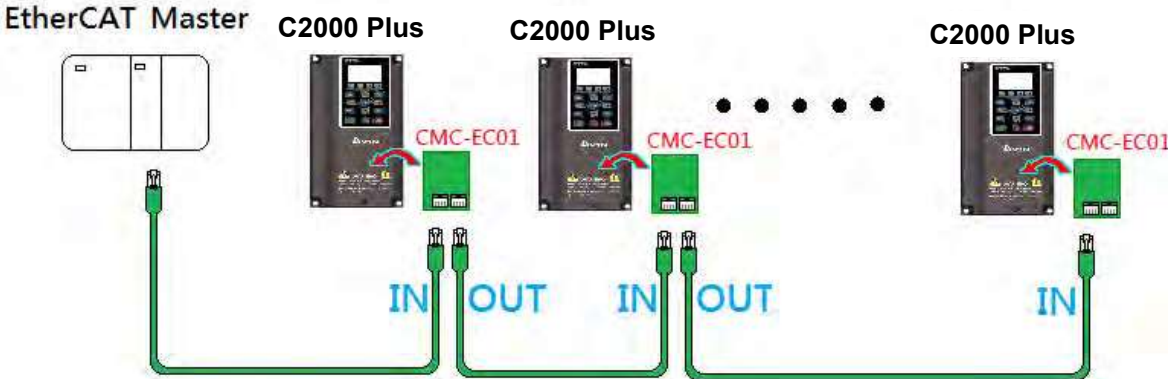

When the hardware is installed and power on, check for the display. The current set value of Pr.09-60 will be 6, and shows “EtherCAT” on the display. If the above information does not show on the display, check the version of C2000 Plus (V3.05 and above) and the connection of the card.



8-16 CMC-PN01 -- Communication card, PROFINET

8-16-1 Features

CMC-PN01 connects C2000 Plus drive to PROFINET to exchange data with the host controller easily. This simple network solution saves cost and time for connection and installation of factory automation. Moreover, its components are compatible with suppliers'.

By installing CMC-PN01 in C2000 Plus through the main PROFINET device, you can:

1. Control the drive through PROFINET
2. Modify the drive's parameters through PROFINET
3. Monitor the drive's status through PROFINET.

8-16-2 Product profile

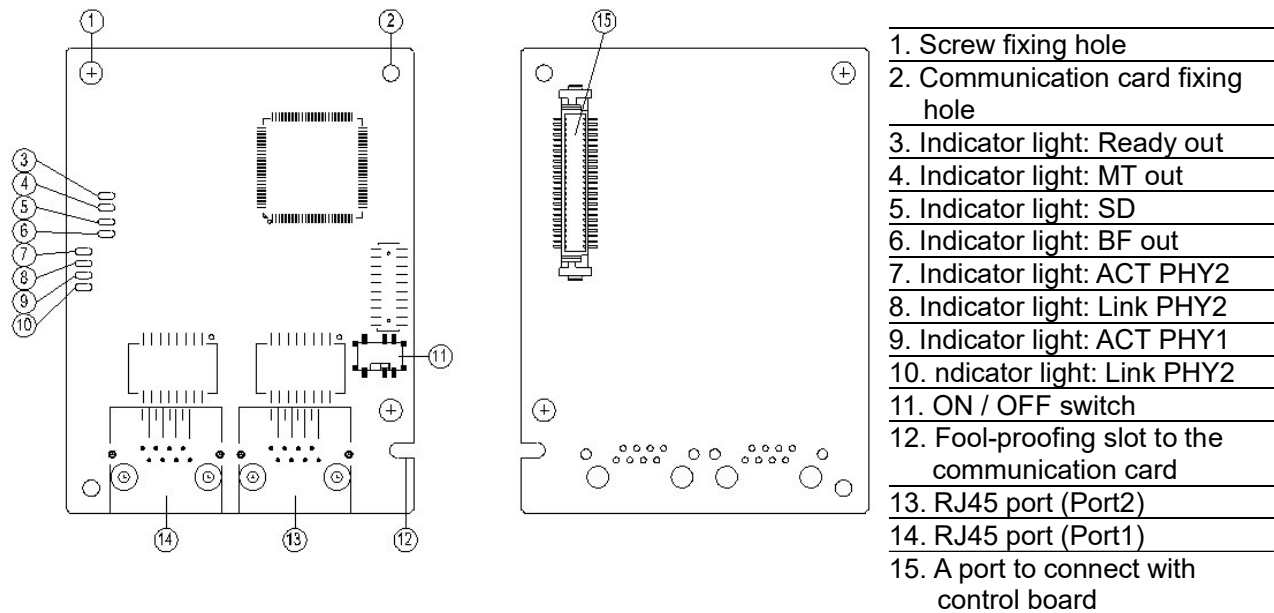

Label with MAC address

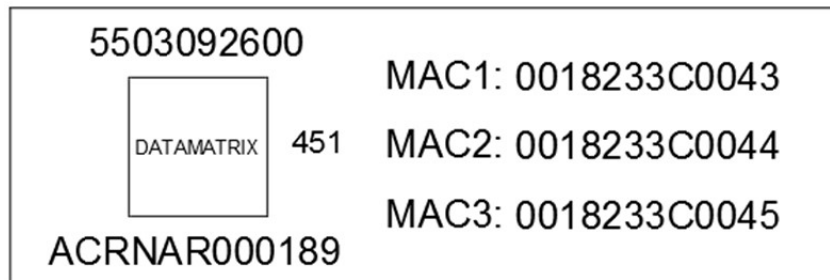

Definition	Description
MAC1	Port 1 MAC Address
MAC2	Port 2 MAC Address
MAC3	Interface MAC Address

8-16-3 Specifications

Network interface

Item	Specifications
Interface	RJ45
Number of ports	2 ports
Transmission cable	IEEE 802.3
Transmission rate	Category 5e shielding 100 M
Communication protocol	10/100 Mbps auto-negotiate
Interface	PROFINET

Electrical specification

Item	Specifications
Power supply voltage	5 V _{DC}
Power consumption	0.8 W
Insulation voltage	500 V _{DC}
Weight (g)	27 (g)

Environmental conditions

Item	Specifications
Noise immunity	ESD (IEC 61800-5-1, IEC 6100-4-2) EFT (IEC 61800-5-1, IEC 6100-4-4) Surge Teat (IEC 61800-5-1, IEC 6100-4-5) Conducted Susceptibility Test (IEC 61800-5-1, IEC 6100-4-6)
Operation and storage	-10–50°C (temperature), 90% (humidity)
Vibration & shock resistance	International Standard: IEC 61800-5-1, IEC 60068-2-6 / IEC 61800-5-1, IEC 60068-2-27

8-16-4 Definition of PINs in RJ45 port

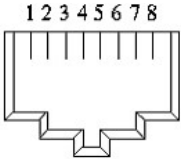
RJ45	PIN	Signal	Definition
	1	Tx+	Positive pole for data transmission
	2	Tx-	Negative pole for data transmission
	3	Rx+	Positive pole for receiving data
	4	--	N/C
	5	--	N/C
	6	Rx-	Negative pole for receiving data
	7	--	N/C
	8	--	N/C

8-16-5 To set the communication parameters when C2000 Plus connects with PROFINET

When you operate C2000 Plus through CMC-PN01, set up the communication card as the source of C2000 Plus controls and settings. You need to use the keypad to configure the following parameter addresses to the corresponding values:

Parameters	Setting value	Description
00-20	8	The frequency command is controlled by communication card
00-21	5	The frequency command is controlled by communication card
09-30	1	Use decoding method (60xx or 20xx)
09-60	12	Communication card identification: When CMC-PN01 communication card is connected, the value of this parameter displays "12".

8-16-6 LED indicator introduction

Name	Indicator status		Indication
Ready out indicator	Yellow LED	Always on	PN Stack starts normally
		Flashing	PN Stack starts normally, and waiting for syncing with MCU
		Off	PN Stack failed to start
MT out indicator	Green LED	-	-
SD indicator	Red LED	-	-
BF out indicator	Red LED	Always on	Connection with PROFINET Controller is interrupted
		Flashing	Connection is in normal state, but the communication with PROFINET Controller is abnormally
		Off	Connection with PROFINET Controller is in normal state
ACT PHY1 indicator	Orange LED	Always on	It's online, and exchanging the data with Master normally
		Flashing	It's offline, but hand shaking the data with Master
		Off	Initial state
LINK PHY1 indicator	Green LED	Always on	Internet connection is in normal state
		Off	Doesn't connect to network
ACT PHY2 indicator	Orange LED	Always on	It's online, and exchanging the data with Master normally
		Flashing	It's offline, but hand shaking the data with Master
		Off	Initial state
LINK PHY2 indicator	Green LED	Always on	Internet connection is in normal state
		Off	Doesn't connect to network

8-16-7 Network connection

The wiring of CMC-PN01 shows as follows:

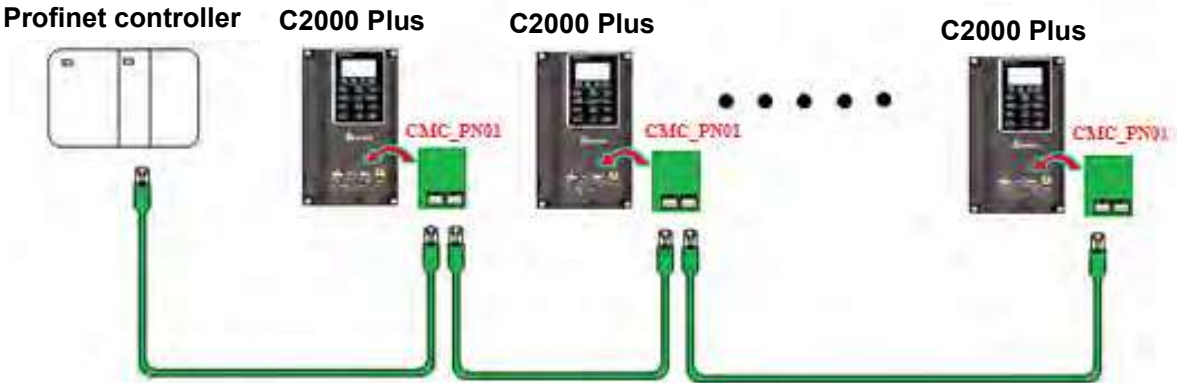

When the installation is finished, supply electricity to the drive. The Pr.09-60 of the drive should be able to display "PROFINET" with a current value of 12. If not, make sure your version of the drive is correct (C2000 Plus needs V3.05 or later versions) and the communication card is correctly connected.



8-17 EMC-COP01 -- Communication card, CANopen

8-17-1 Terminating Resistor Position

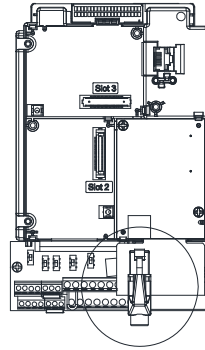
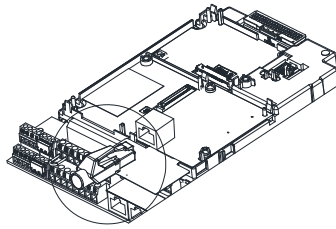

8-17-2 RJ45 Pin Definition

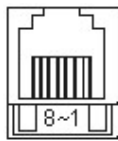

RS485 socket

Pin	Pin name	Definition
1	CAN_H	CAN_H bus line (dominant high)
2	CAN_L	CAN_L bus line (dominant low)
3	CAN_GND	Ground / 0V / V-
7	CAN_GND	Ground / 0V / V-

8-17-3 Specifications

Interface	RJ45
Number of ports	1 Port
Transmission method	CAN
Transmission cable	CAN standard cable
Transmission speed	1 Mbps, 500 Kbps, 250 Kbps, 125 Kbps, 100 Kbps, 50 Kbps
Communication protocol	CANopen

8-18 Delta Standard Fieldbus Cables

Delta Cables	Part Number	Description	Length
CANopen Cable / RJ45 extension cable for keypad	UC-CMC003-01A	CANopen cable, RJ45 connector	0.3 m
	UC-CMC005-01A	CANopen cable, RJ45 connector	0.5 m
	UC-CMC010-01A	CANopen cable, RJ45 connector	1 m
	UC-CMC015-01A	CANopen cable, RJ45 connector	1.5 m
	UC-CMC020-01A	CANopen cable, RJ45 connector	2 m
	UC-CMC030-01A	CANopen cable, RJ45 connector	3 m
	UC-CMC050-01A	CANopen cable, RJ45 connector	5 m
	UC-CMC100-01A	CANopen cable, RJ45 connector	10 m
	UC-CMC200-01A	CANopen cable, RJ45 connector	20 m
DeviceNet Cable	UC-DN01Z-01A	DeviceNet cable	305 m
	UC-DN01Z-02A	DeviceNet cable	305 m
EtherNet / EtherCAT Cable	UC-EMC003-02A	Ethernet / EtherCAT cable, Shielding	0.3 m
	UC-EMC005-02A	Ethernet / EtherCAT cable, Shielding	0.5 m
	UC-EMC010-02A	Ethernet / EtherCAT cable, Shielding	1 m
	UC-EMC020-02A	Ethernet / EtherCAT cable, Shielding	2 m
	UC-EMC050-02A	Ethernet / EtherCAT cable, Shielding	5 m
	UC-EMC100-02A	Ethernet / EtherCAT cable, Shielding	10 m
	UC-EMC200-02A	Ethernet / EtherCAT cable, Shielding	20 m
CANopen / DeviceNet TAP	TAP-CN01	1 in 2 out, built-in 121 Ω terminal resistor	1 in 2 out
	TAP-CN02	1 in 4 out, built-in 121 Ω terminal resistor	1 in 4 out
	TAP-CN03	1 in 4 out, RJ45 connector, built-in 121 Ω terminal resistor	1 in 4 out, RJ45
PROFIBUS Cable	UC-PF01Z-01A	PROFIBUS DP cable	305 m